



User Manual



Embroidery Hooping
MADE EASY!™



www.Allin1Hooper.com



Thank You

TEX  **INC**
Embroidery Innovators

Thanks you for purchasing the
All In 1 Hooper Pro.

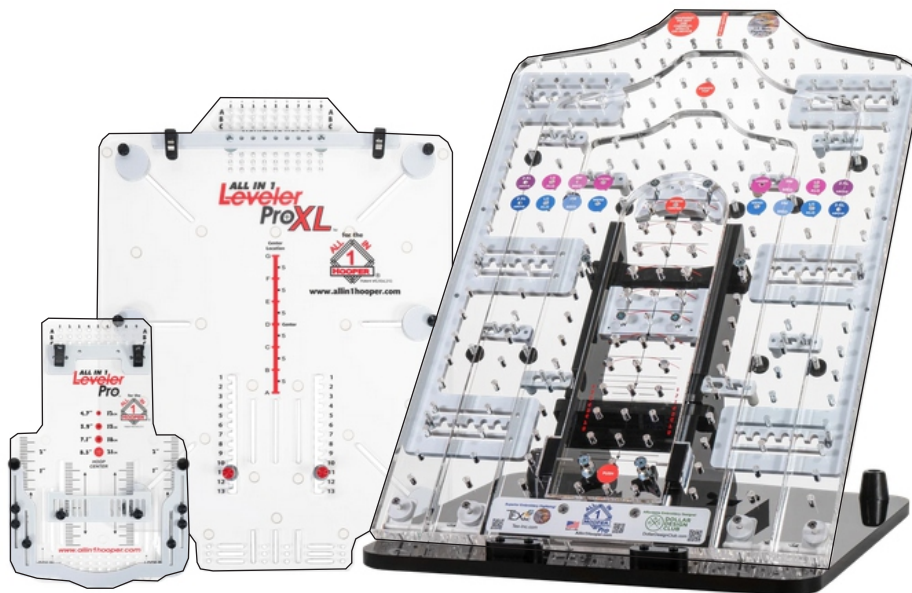

Register your device online at
www.learnallin1.com



**REGISTER
DEVICE**



Contents

SECTIONS		PAGE
1	Learning Center	1
2	Cleaning The All in 1 Hooper Pro	2
3	Package Content	3
4	Assembling the All in 1 Hooper Pro	4-8
5	Securing the All in 1 Hooper Pro	9
6	Releasing Board Sizes	10
7	Placement - Color Stickers - Hooping	11-12
8	Leveler Pro Small Hoops	13-22
9	Leveler Pro XL Large Hoops	23-25
10	Sleeve Board Pro	26-31
10	TEX INC Support	32



Learning Center



**LEARNING
CENTER**

www.learnallin1.com

The Learning Center offers helpful videos and downloadable guides to maximize your hooping experience with the All in 1 Hooper. Explore step-by-step tutorials, tips, and tricks to become a hooping pro. Don't forget, we are just an email or phone call away for any additional support you may need.



Assembling the Hooper

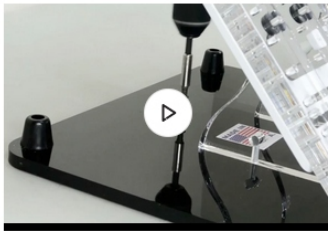

Securing the Hooper



Functions of the Hooper



Using the Leveler Pro



Using the Leveler Pro XL

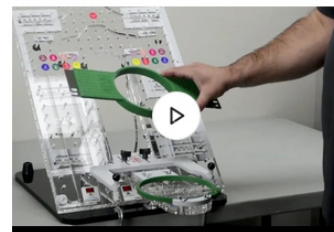

Using the Sleeve Board Pro

Downloads

All in 1 Hooper User Manual 

Leveler Pro & XL User Manual 

(Stand Alone Model)
Sleeve Board Pro User Manual 



Cleaning

WARNING!

The All In 1 Hooper is made from high-quality, durable acrylic. However, acrylic is a sensitive material that can shatter if struck hard or exposed to chemical solvents, causing spider cracking. Please follow these guidelines to maintain its condition and avoid voiding your warranty.

Important Notice for Acrylic Parts:

Main Board, Sleeve Board, Leveler Pro & XL, and Sleeve Support are all acrylic and can crack if not cared for properly.

Avoid Harmful Products:

Do not use cleaning products containing Methanol, Isopropyl, Acetone, MEK, or any alcohol-based substances. Do not use Windex.

Proper Cleaning Method:

- Use a clean, lint-free cloth.
- Apply a mild soap solution to the cloth.
- Gently clean the acrylic surface.
- Rinse with warm water.
- Allow the surface to air dry.



Recommended Cleaner:

For optimal results, we recommend using Craftics 20/20 Plastic Cleaner, which is specially formulated for acrylic surfaces. For more information, please visit www.craftics.com.

By following these guidelines, you can ensure the longevity and appearance of your All In 1 Hooper.

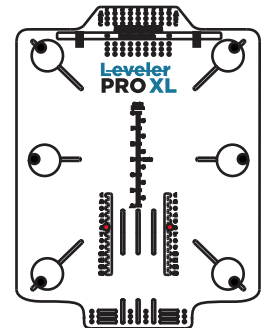
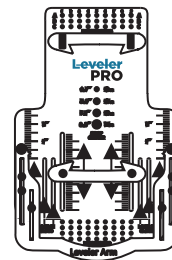
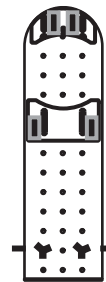
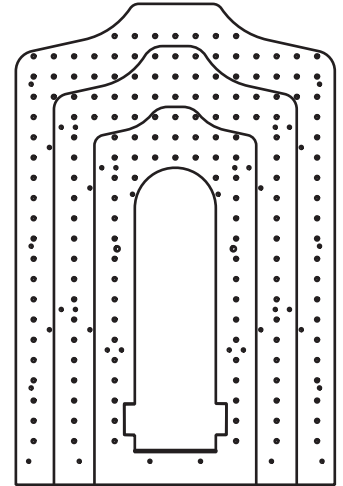



Package Content

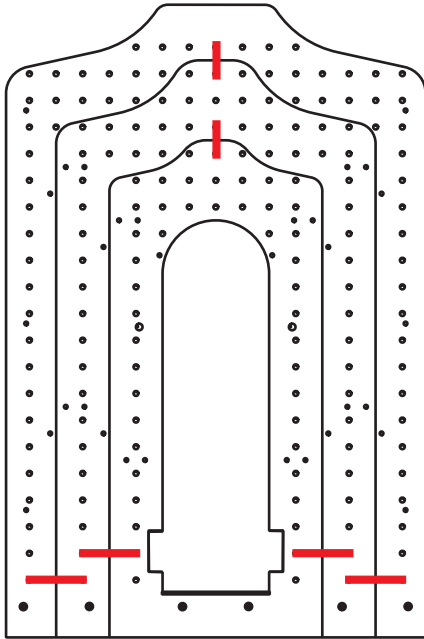

Main Board (1)

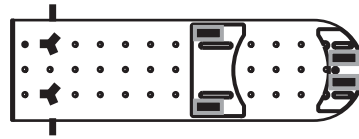

Sleeve Board & Support (1 ea)

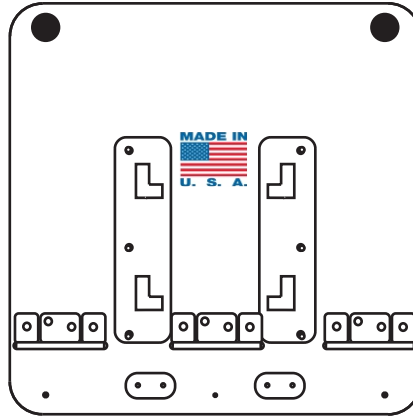

Base (1)

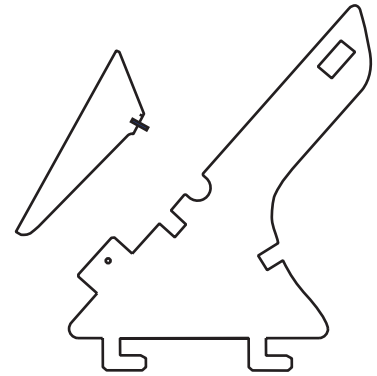

Allin1Hooper Braces (2)



Brace Support Bars (2)



Brace Support Bar3 (1)

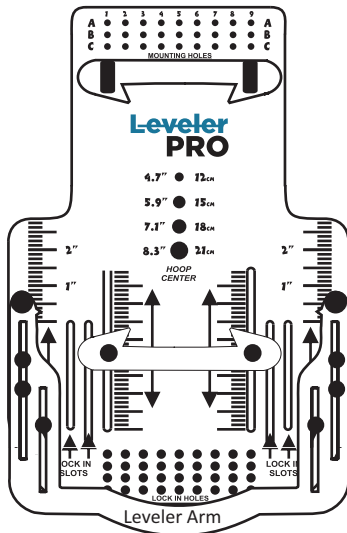

LevPro - Small Hoops (1)

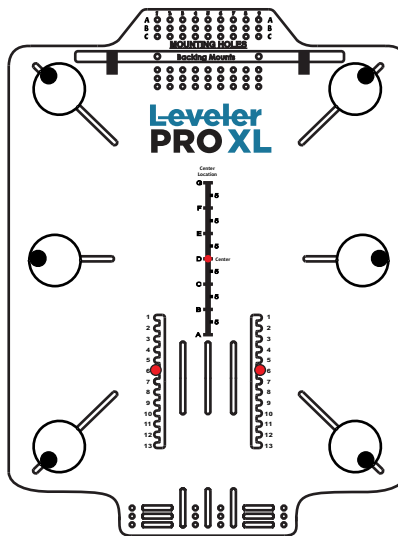

LevPro XL - Large Hoops (1)

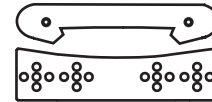

Lp18cm / SQ / Bro Hoops (1)

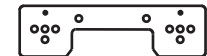

Magnetic Hoops (1)

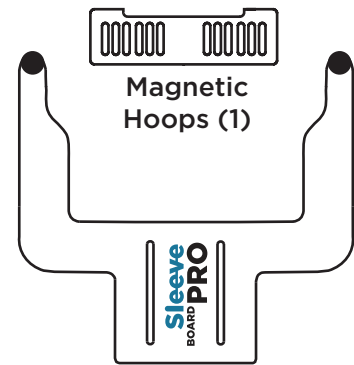

Sleeve Board Pro (1)

LevPro & XL Screw Kit



(4) Screws - (4) Wing Nuts (4) Pins

Assembly & Securing Screw Kit

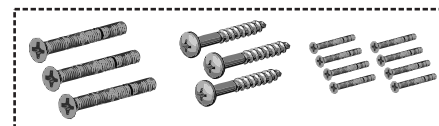

(3) Brace Screws - (3) Base Screws (8) Hinge Screws

Please contact us if items are missing.

sales@allin1hooper.com - 480-375-1844 text/call

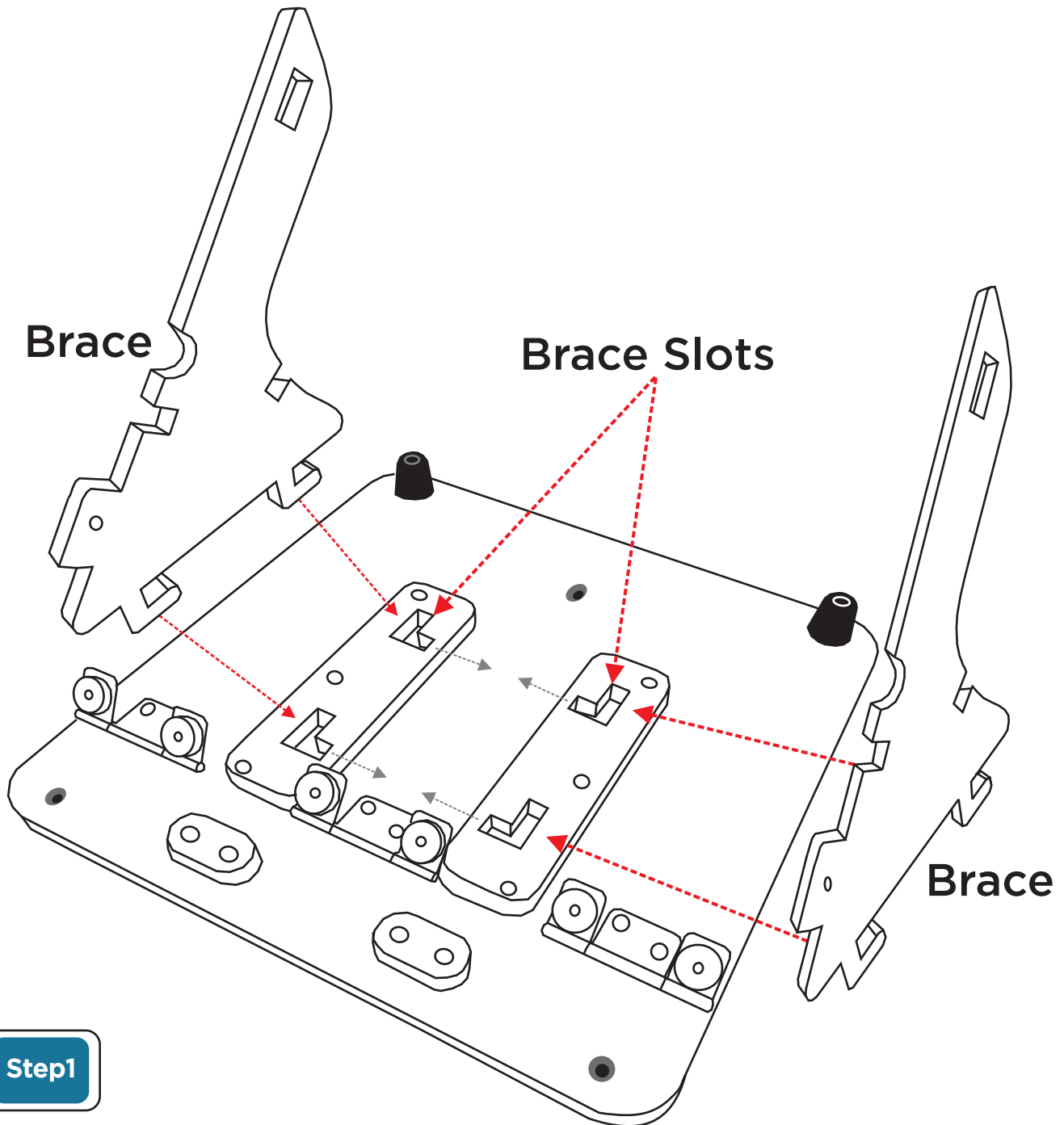

Step1

Insert braces into base slots then push braces inward toward center.

Assembling

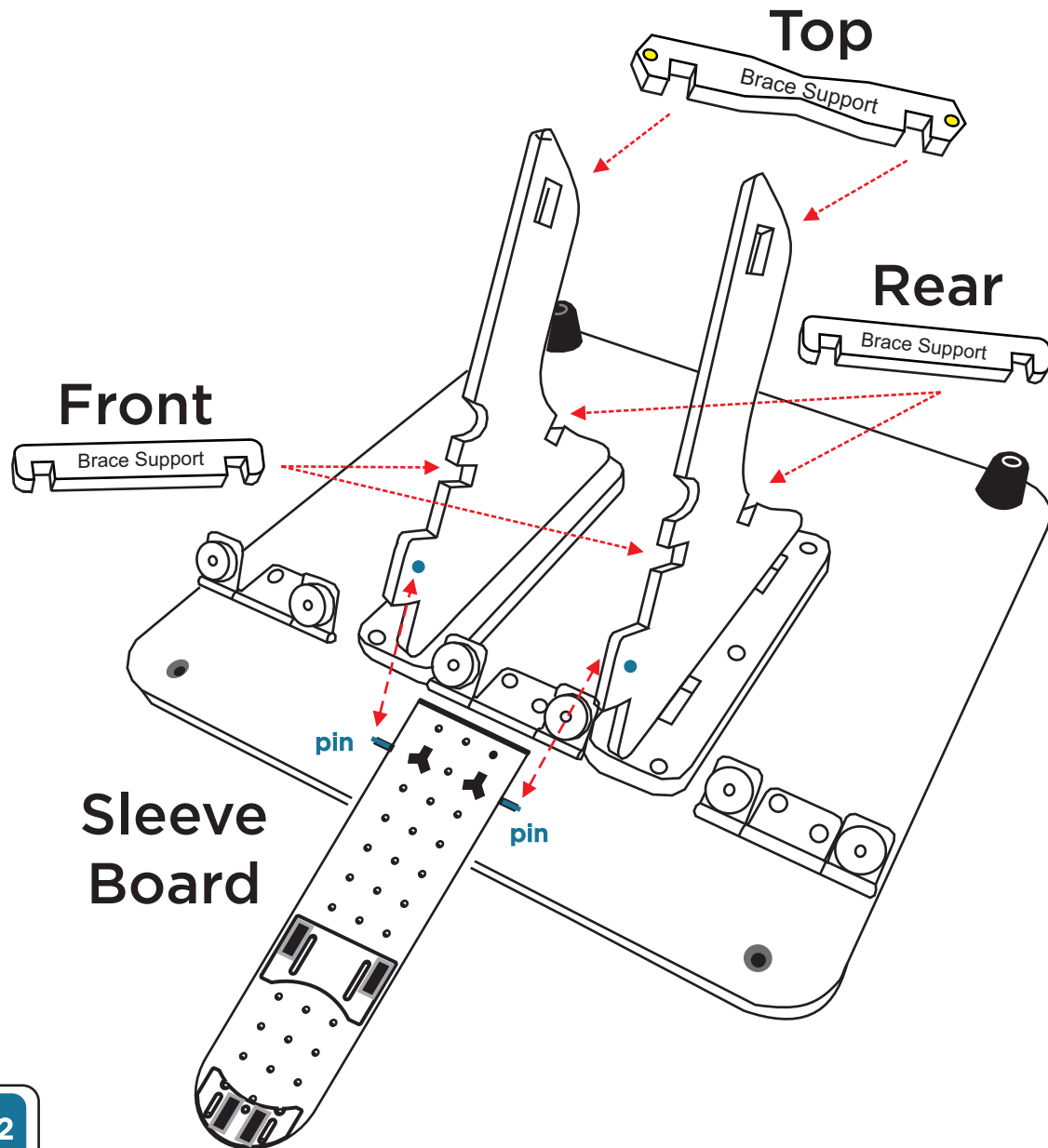

Step2

Insert the sleeve board pins into the holes on the inside of the braces (shown in blue). Then insert the three brace support bars to lock the braces together. The brass nut on the top support bar faces to the back of the device (front & rear bars are interchangeable). Lift Sleeve Board into the upright position.

Assembling

Main Board

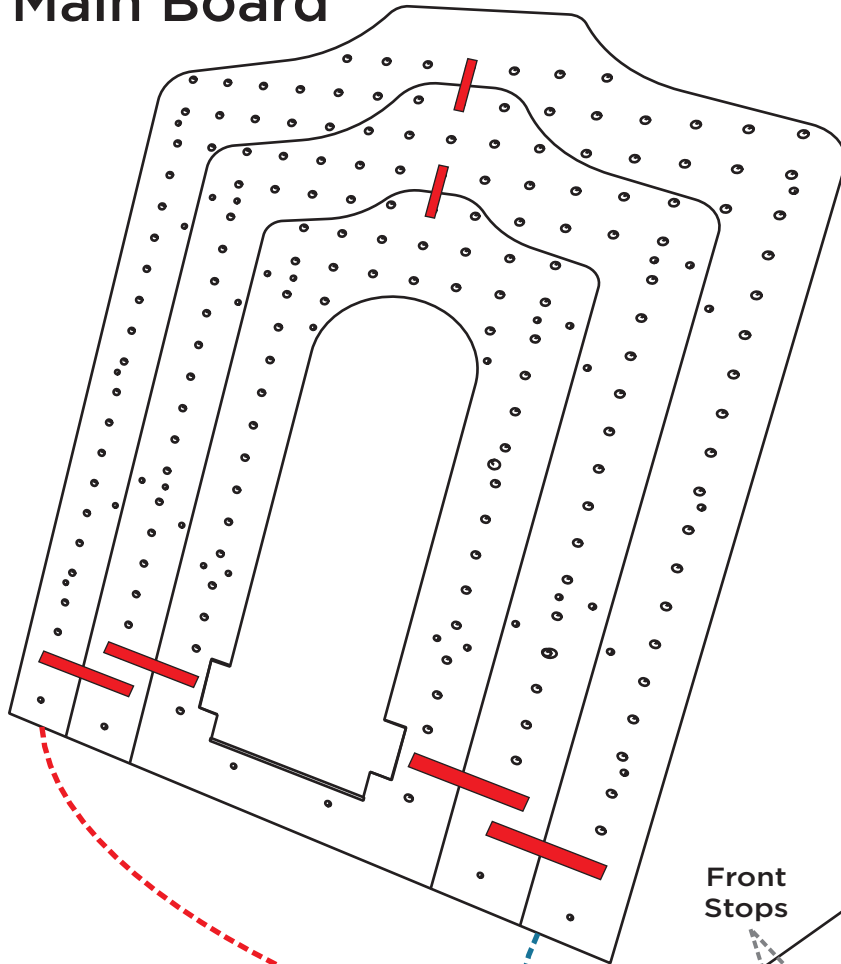

Sleeve Board

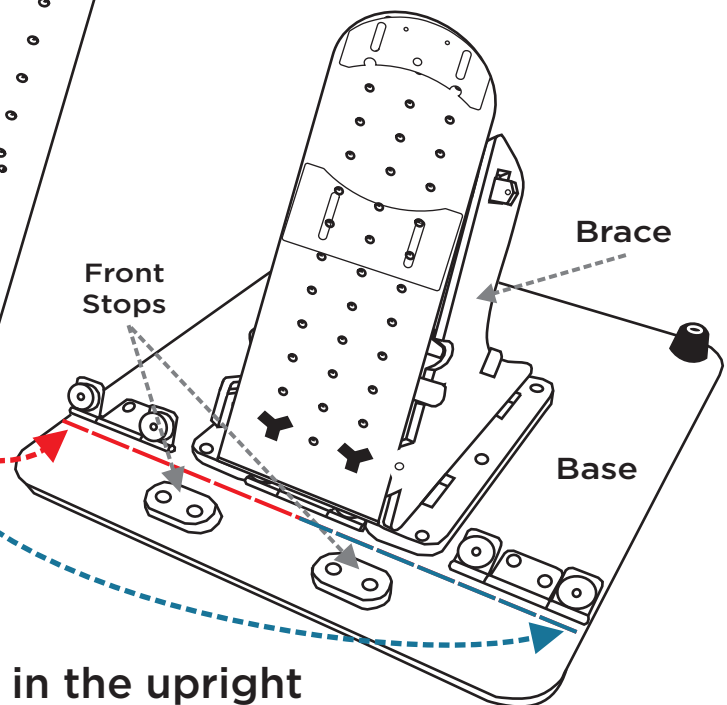

Step 3

Make sure the sleeve board is in the upright position. Place All in 1 Hooper main board onto the base plate aligned between front stops and back braces (shown above with red dotted line on base). Start to lower the main board and simultaneously pull up the sleeve board slightly forward through the main board opening. Then lay the main board and sleeve board back onto the braces.

Assembling

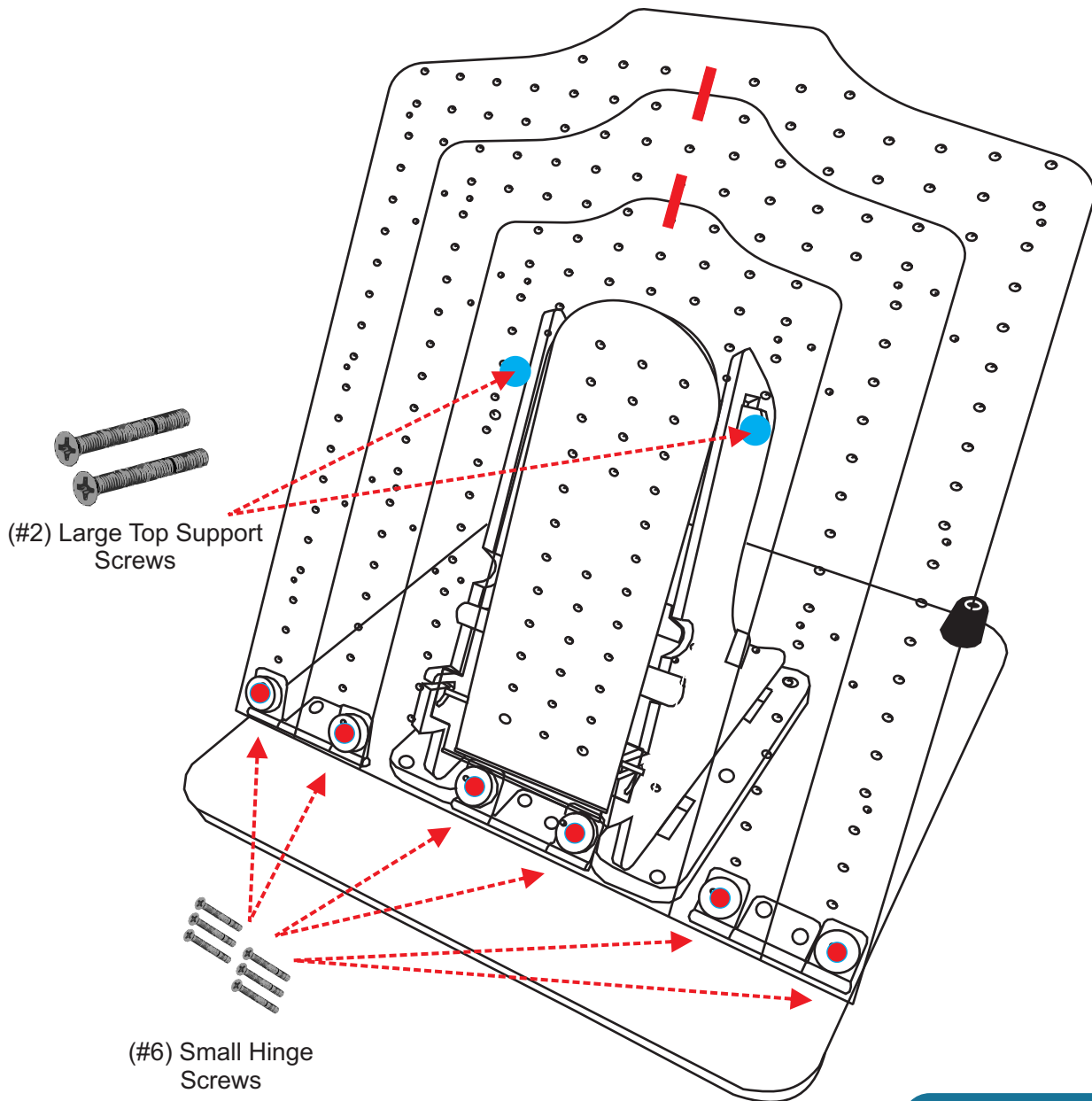

Step 4

Tool Needed
Phillip Screwdriver

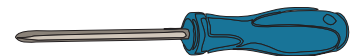

Using a Phillip head screw driver, insert top support screws (#2) and slightly tighten. Insert bottom screws (#6) & fully tighten. Then fully tighten the top support screws.

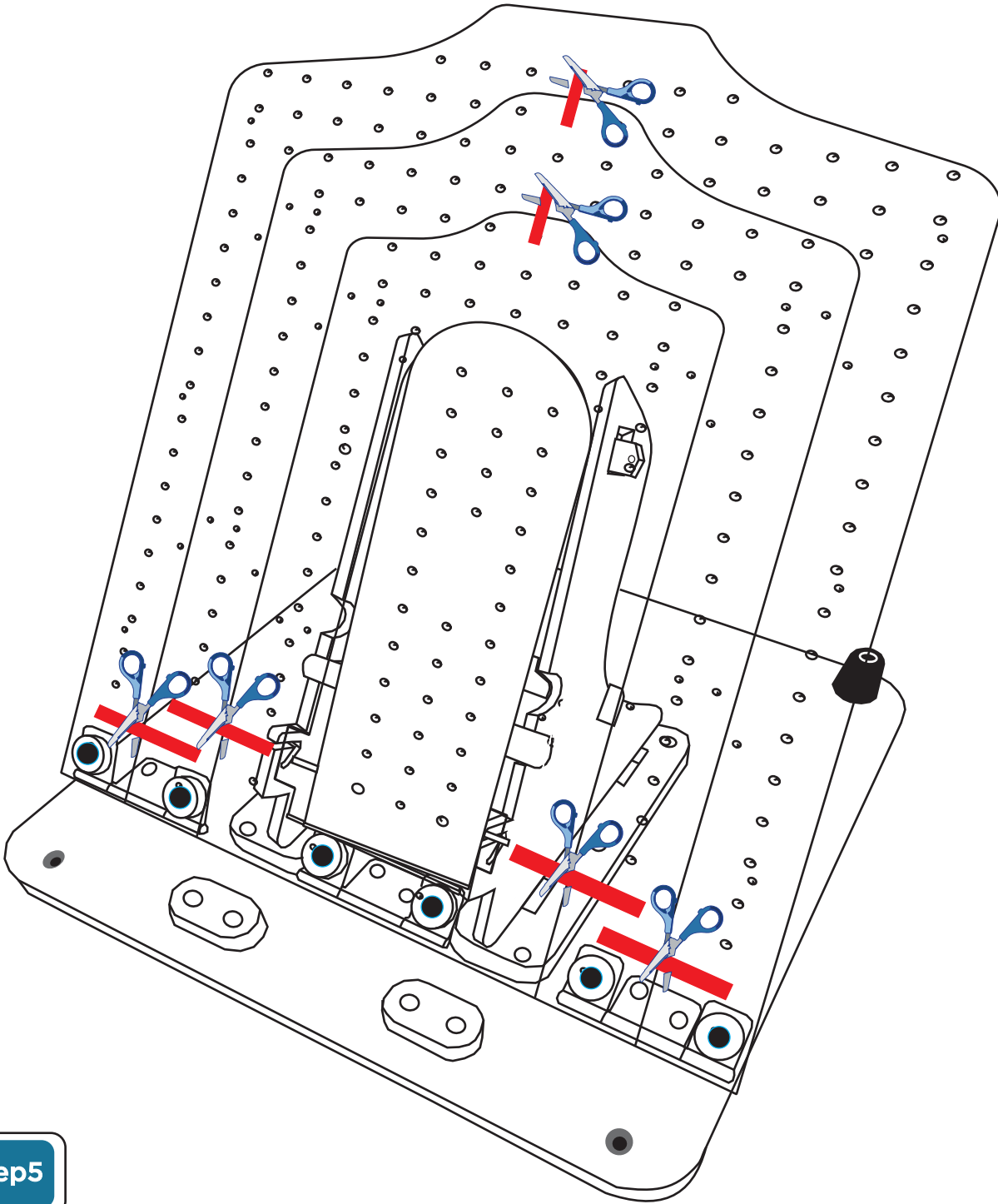

Step5

The last step is removing all six red zip ties with a scissor.

Securing

WARNING!

The All in 1 Hooper Pro needs a 26" clearance from the wall when adult board is collapsed back.

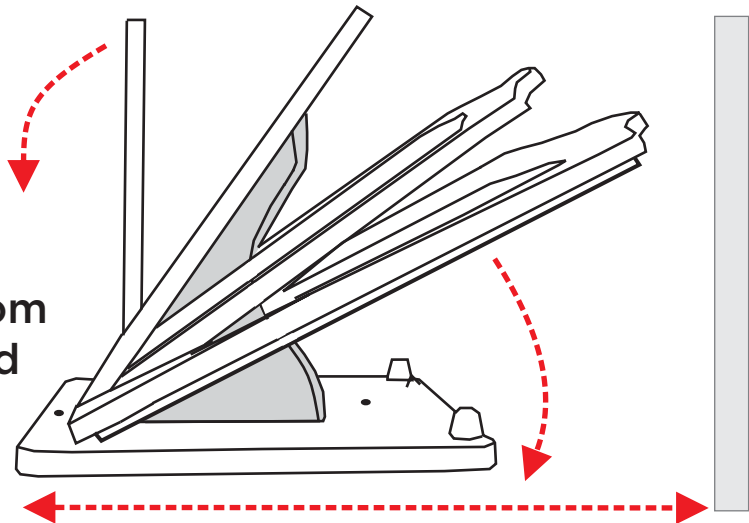

The All in 1 Hooper Pro should be securely fastened to a sturdy work surface. Enclosed are three wood screws. Two screws are mounted to the front base and one in the back center (shown in red circles below). The back screw is a must because when the sleeve board is out the device will tip forward. A set of c-clamps can be used in lieu of screws if desired.

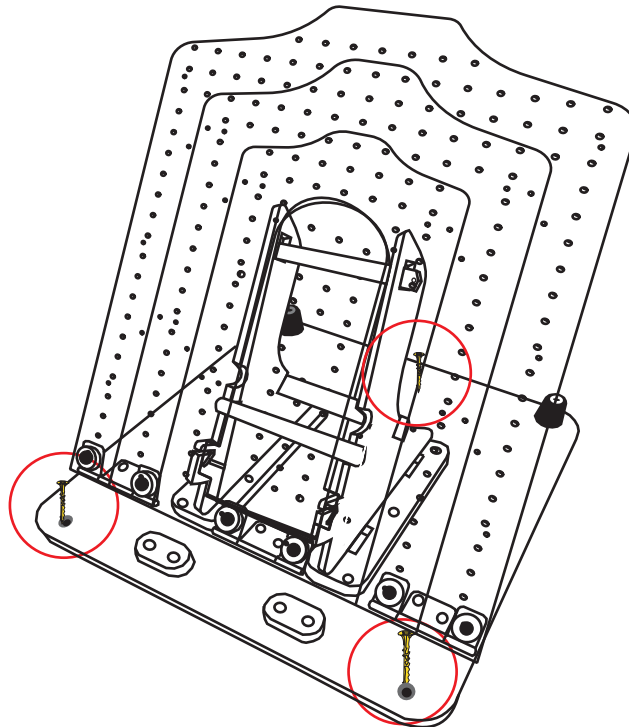

Releasing Board Size

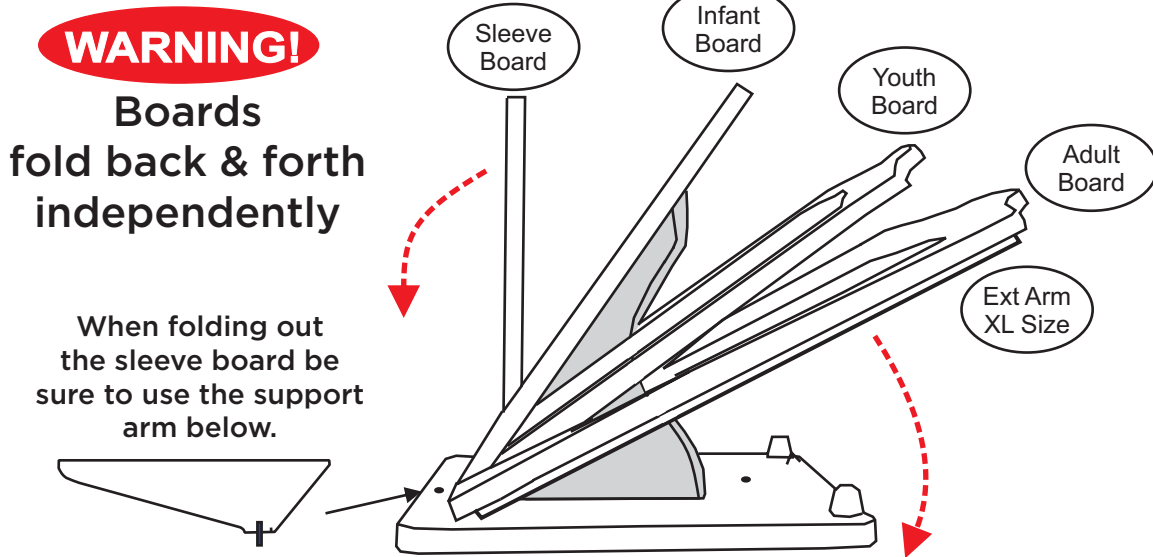

Slide Locks

The All in 1 Hooper Pro has eight slide locks, four on each side of the device. To unlock each board size slide the locks toward center of device.

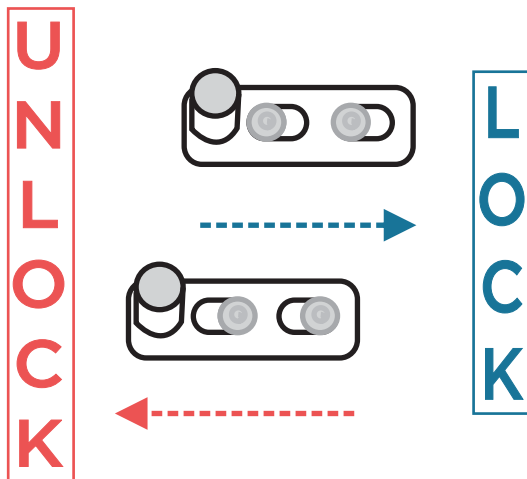

Extension Arms

Extension Arms are used for garments that are larger than the main board 2XL & up.

Lift up
Ext Arm
and pull
outward

To secure the extension arm insert a pin into the main board bottom hole. This will help lock the extension arm in place when pulling garment over top of device.

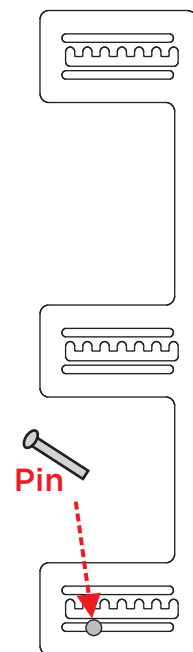

Placement

Ladies & Mens - Left or Right Chest

LEFT or RIGHT chest industry standard placement locations.
If needed you can go up or down depending on garment type.

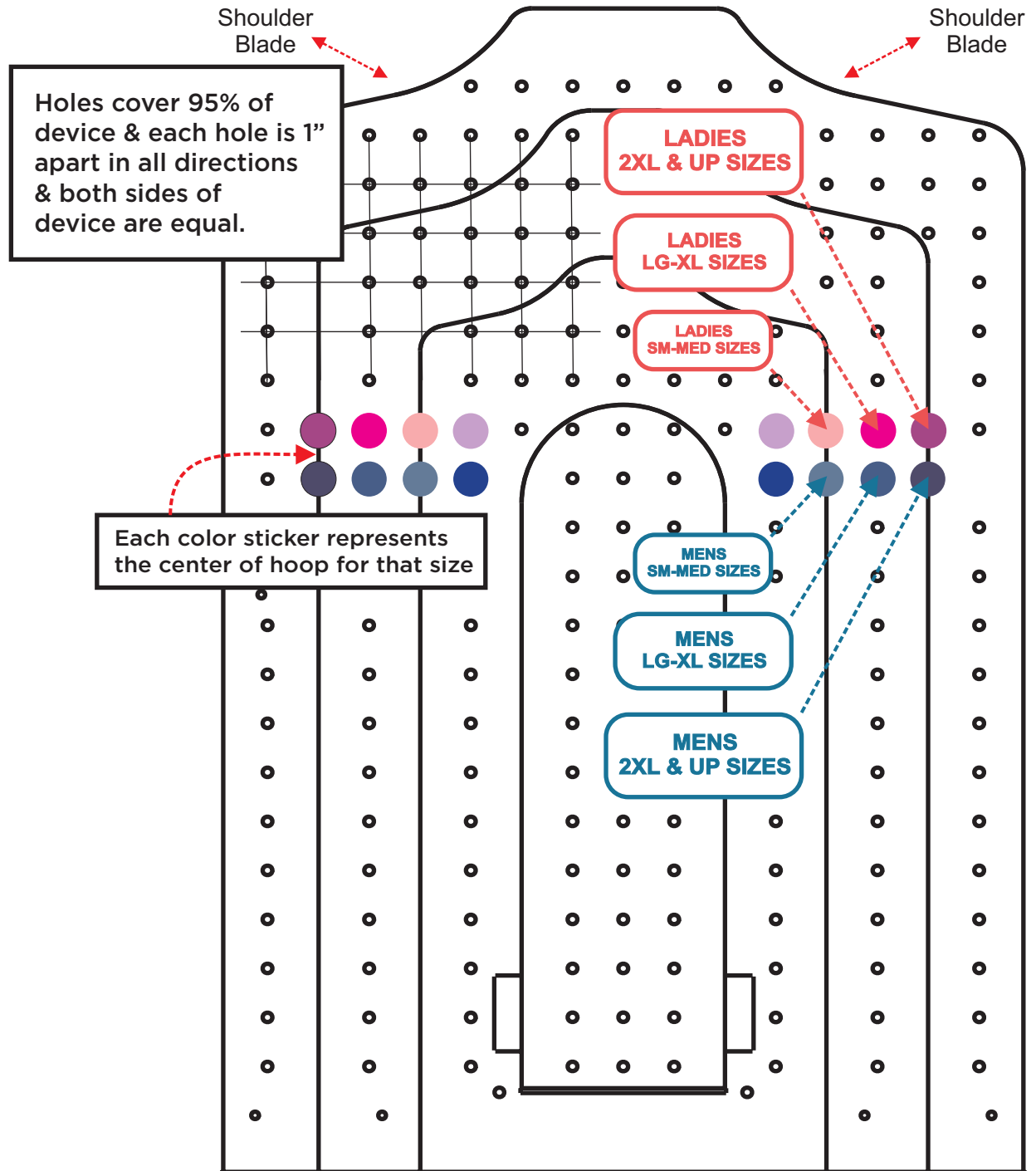

Leveler PRO



If your hoops have a small metal bracket like the example shown to the left you will not have to do anything to your hoops.

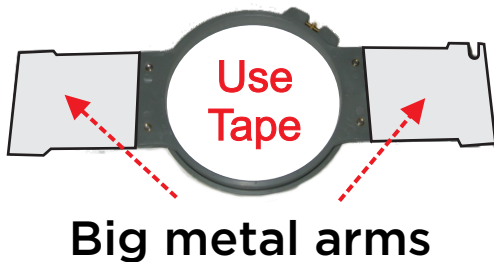

If you are using a style of round, square & oval tubular hoops that are similar to the one shown to the left you will need to perform Step 1 below prior to using these hoops.

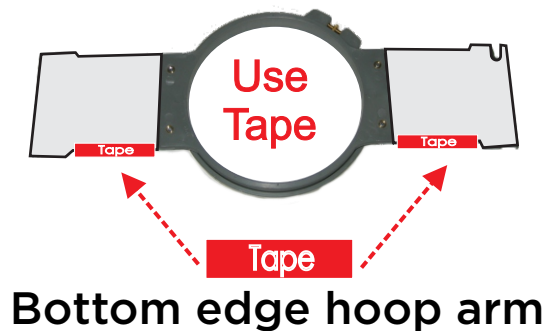

(Step 1)
This style of hoop has metal arms which when applied to the Leveler Arm can cause damage to your garments. To prevent this from happening we suggest placing a piece of masking tape over the bottom edge of the hoop arm. (Example image shown to the left)

Quick Change for Small Tubular Hoops

Place hoop size crosshair over the color coded sticker on main board.

Hoop Center & Hoop Size
5.9" = 15cm **+**

Ruler lines keep leveler arm & bottom bracket straight on both sides.

Leveler arm ball rest will help keep hoop arms straight when pushing in hoop

After moving the leveler arm, tighten the thumb screws to lock it in place

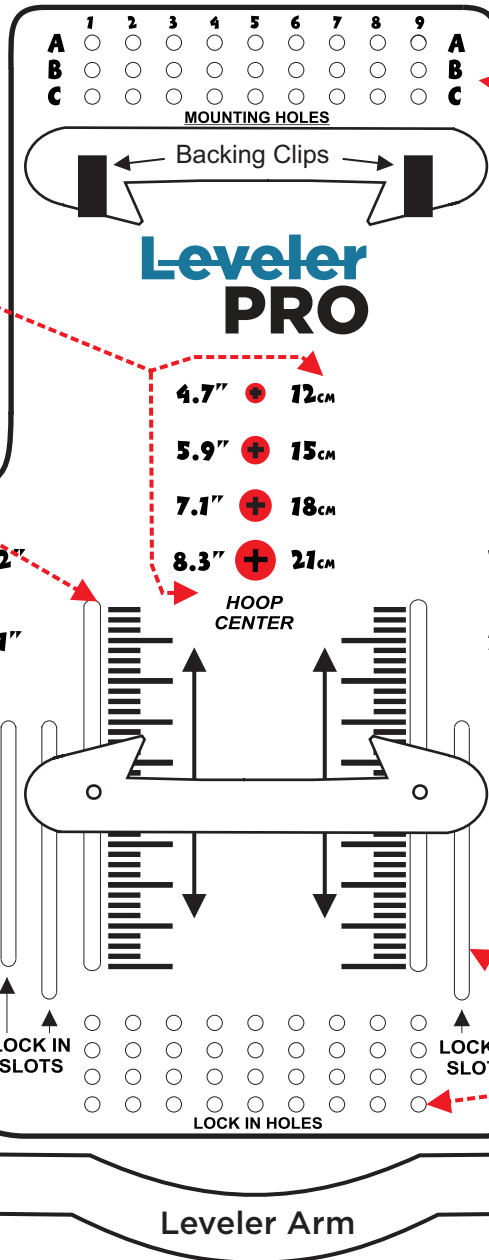

Mounting holes to main board A-B-C marking are used to move the Lev Pro up or down in smaller 1/4" increments.

Leveler Arm Tooth

Used to help read where ruler markings are.

Insert a pin into Lock Slots & Lock Holes which stops the Leveler Pro from shifting.

Leveler Pro

Extra Brackets for Small Hoops

Replace top & bottom bracket on the Leveler Pro & Pro XL for larger round hoops, square hoops & magnetic hoops.

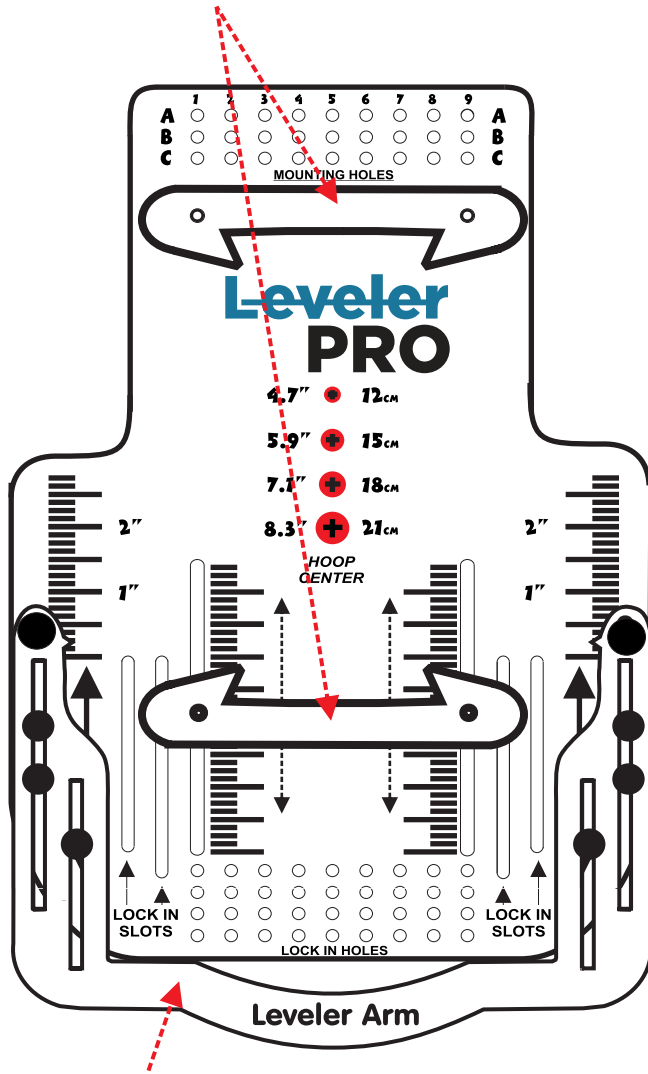

When using square or magnetic hoops you do not need to raise the leveler arm because the tubular hoop arm will automatically be straight. Loosen the thumb screws and pull leveler arm down out of the way and tighten screws.

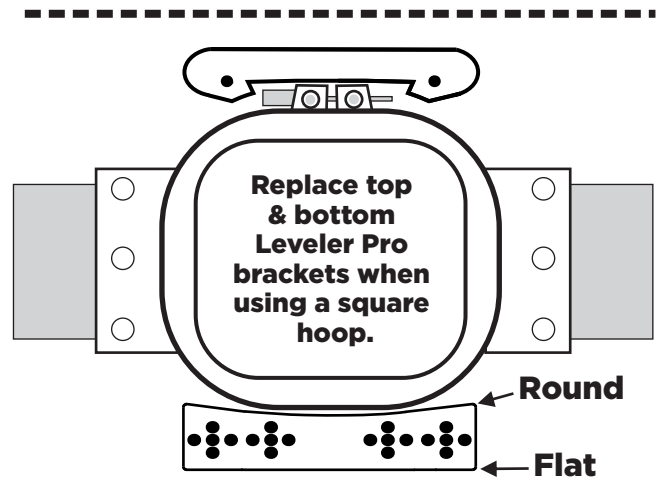

Flip over bottom bracket if you are needing a flat or rounded side.

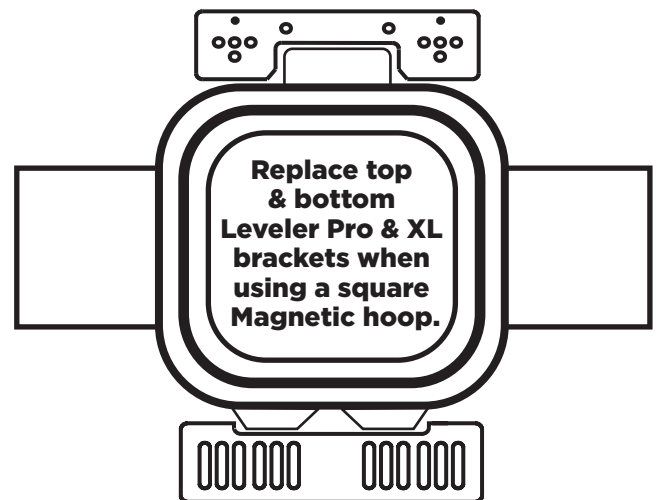

Works with Small & Large Magnetic Hoops on the LevPro & LevPro XL

Leveler Pro & Pro XL

Magnetic Hoop Bracket

Quick Change for Small & Large Magnetic Hoops

Replace top & bottom bracket on the Leveler Pro & Leveler Pro XL for small and large magnetic hoops.

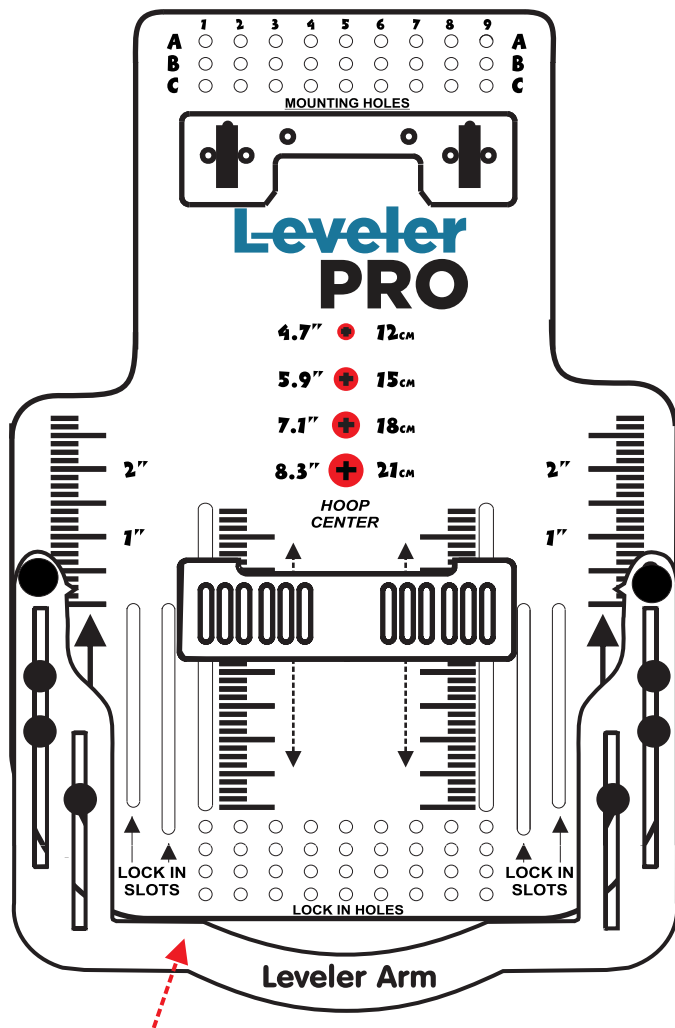

When using square or magnetic hoops you do not need to raise the leveler arm because the tubular hoop arm will automatically be straight. Loosen the thumb screws and pull leveler arm down out of the way and tighten screws.

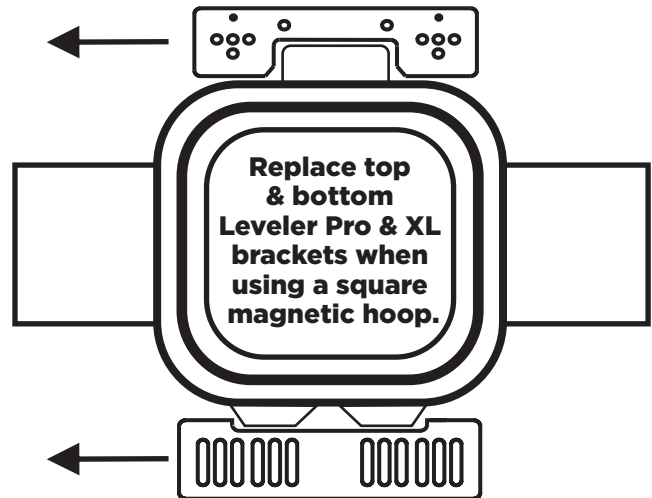

Works with small & large magnetic hoops on the Leveler Pro & Leveler Pro XL

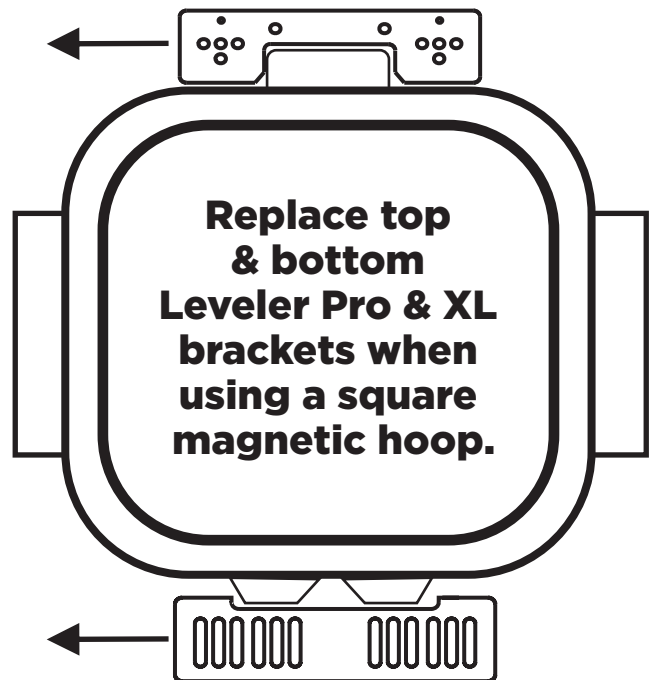

Leveler Pro

Mounting for Small Hoops

Step 1

Insert 2 pins into the top mounting holes A-B-C markings are used to move the Leveler Pro up or down in smaller 1/4" increments.

Step 2

Insert a pin into either the lock hole or lock slots at the bottom of the leveler pro to help stop it from shifting side to side.

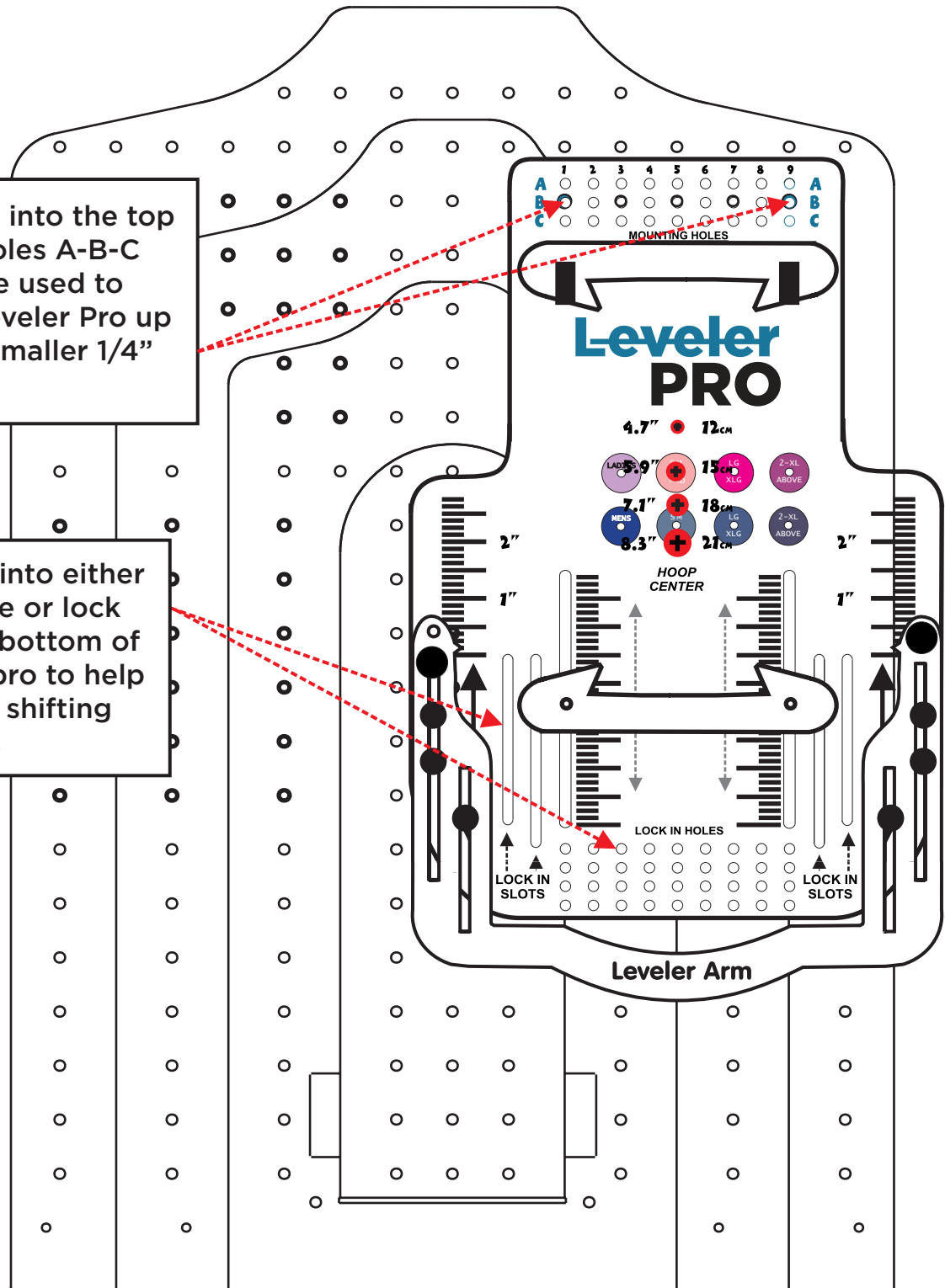

Leveler Pro

Using with Small Hoops

Step 1

Place hoop ring on bottom bracket.

Step 2

Slide up bottom bracket & tighten thumb screws. Make sure bracket is straight on both sides using ruler lines below it.

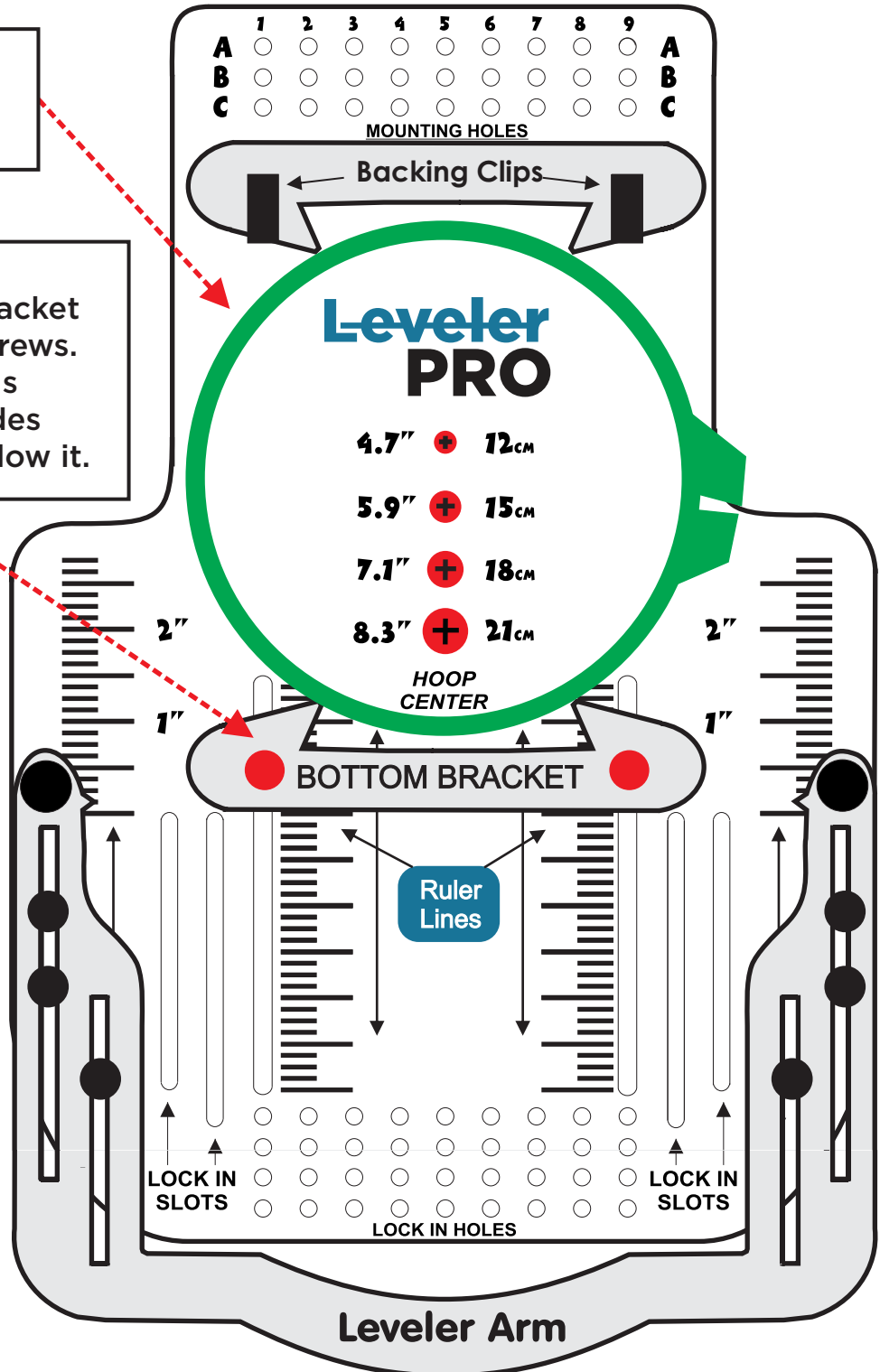

Leveler Pro

Using with Small Hoops

Step 1

Place inner hoop into hoop ring. Loosen leveler arm thumb screws. Slide up the leveler arm so that the black ball is resting under the tubular arm.

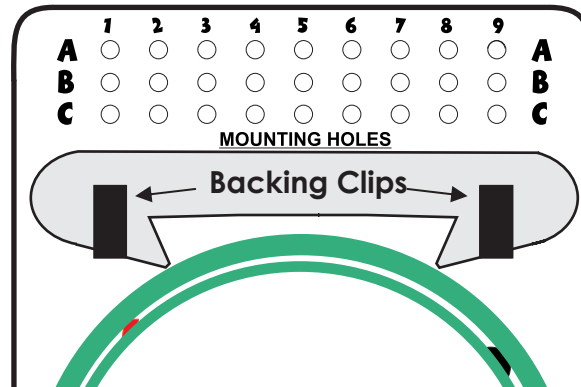

TUBULAR ARM

TUBULAR ARM

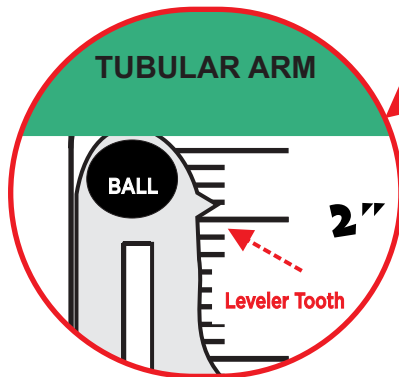

Step 2

At the top of the leveler arm next to the black ball is a leveler tooth. Make sure each tooth is on the same ruler marking then tighten all 6 thumb screws.

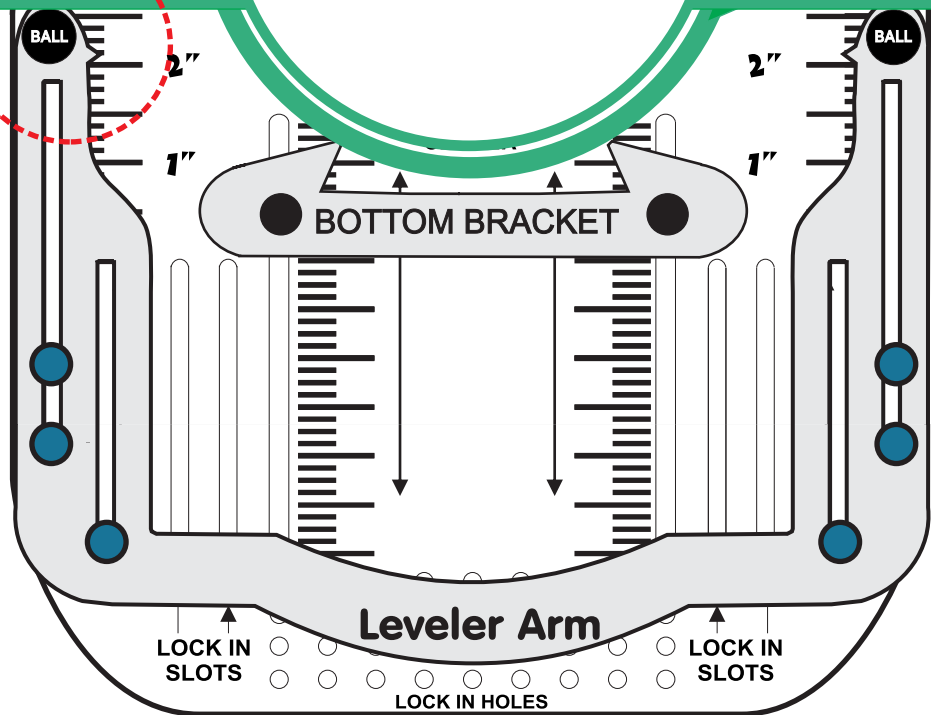



Leveler Pro

Ready to Hoop with Small Hoops

Step 1

Take off top hoop and place an 8x8 piece of backing into the backing clips.

Step 2

Slide garment over device then insert top hoop by resting the bottom inner hoop into the hoop ring & onto black ball on each side of tubular arm.

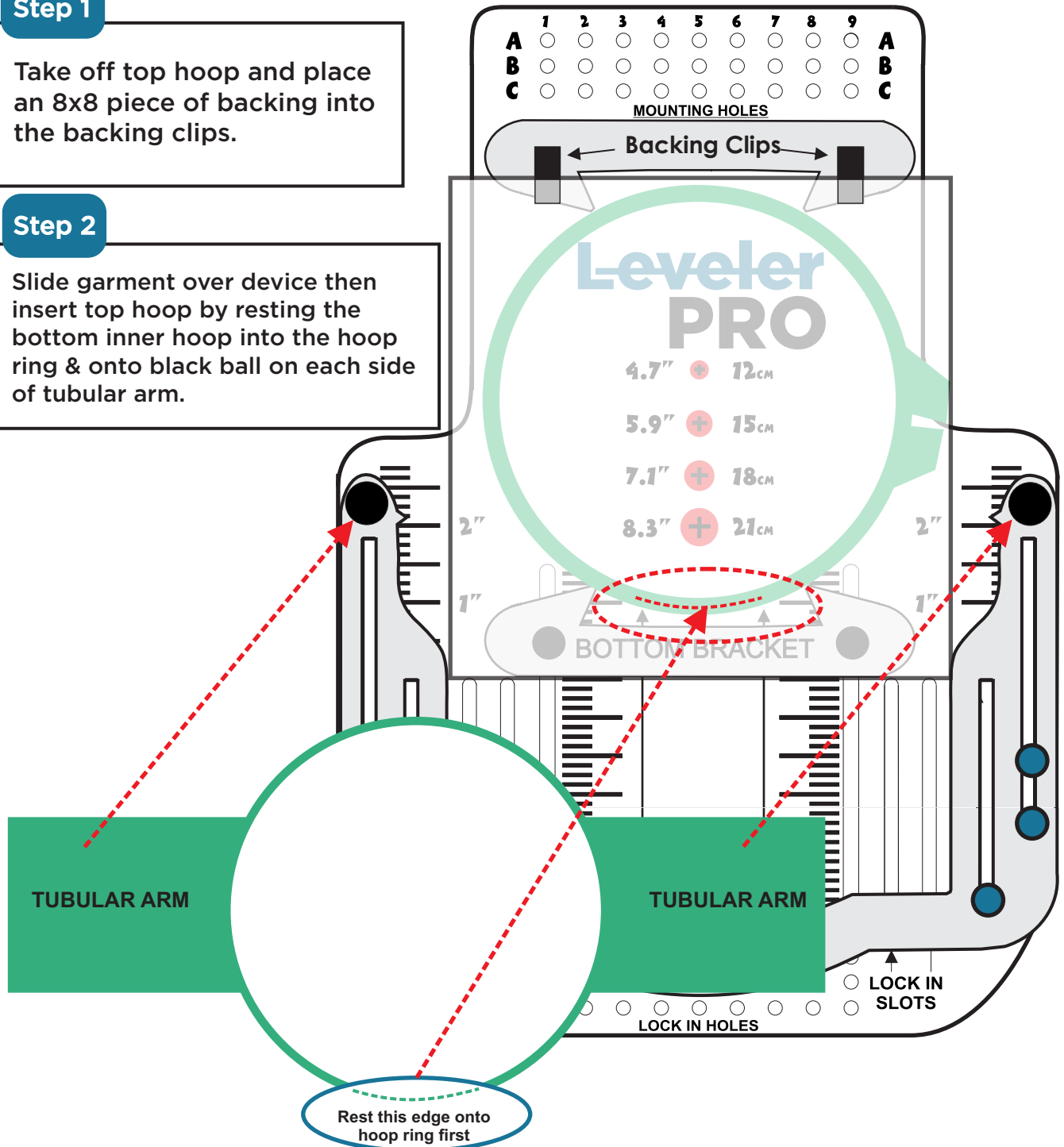



Leveler Pro

Job Placement Card for Small Hoops

THREE EASY STEPS TO REPEATING YOUR ORDERS

Customer Name JANE DOE Job Design Name JD 1

Type of Garment SWEATSHIRT SCOPE NECK

Embroidery Location LEFT CHEST

Garment Size ----- Youth ___ Adult X ----- Ladies X Mens ___

Board Size ----- Infant ___ Youth ___ Adult X

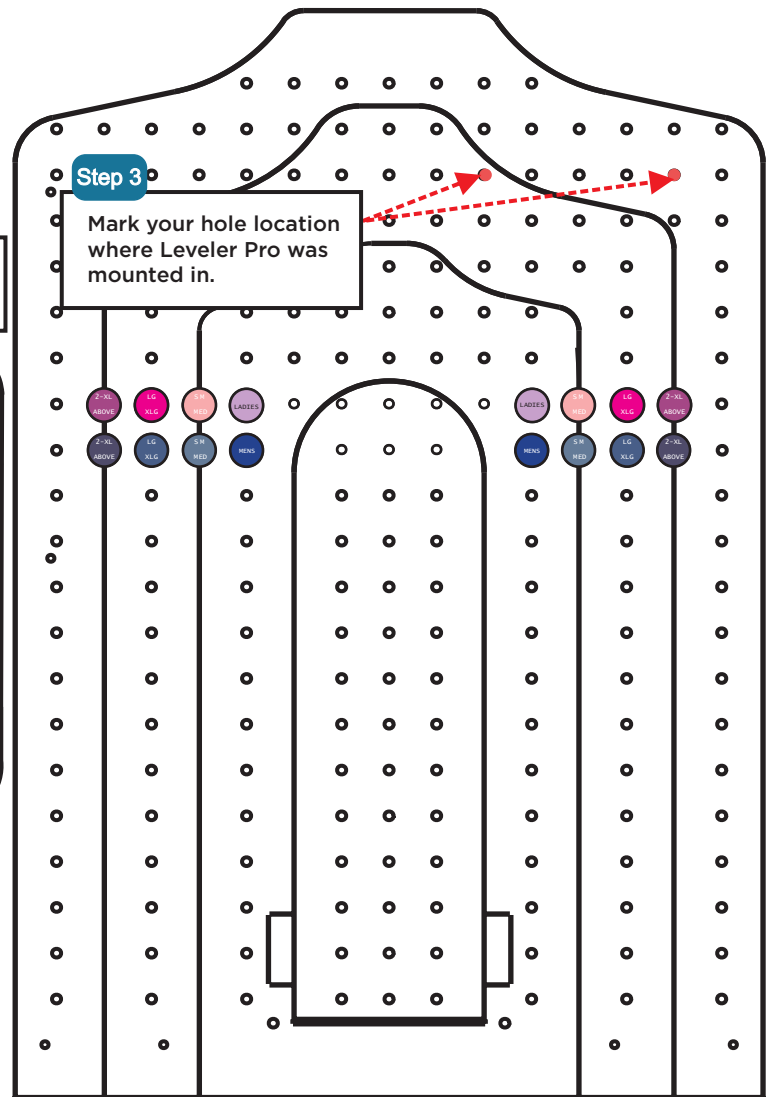
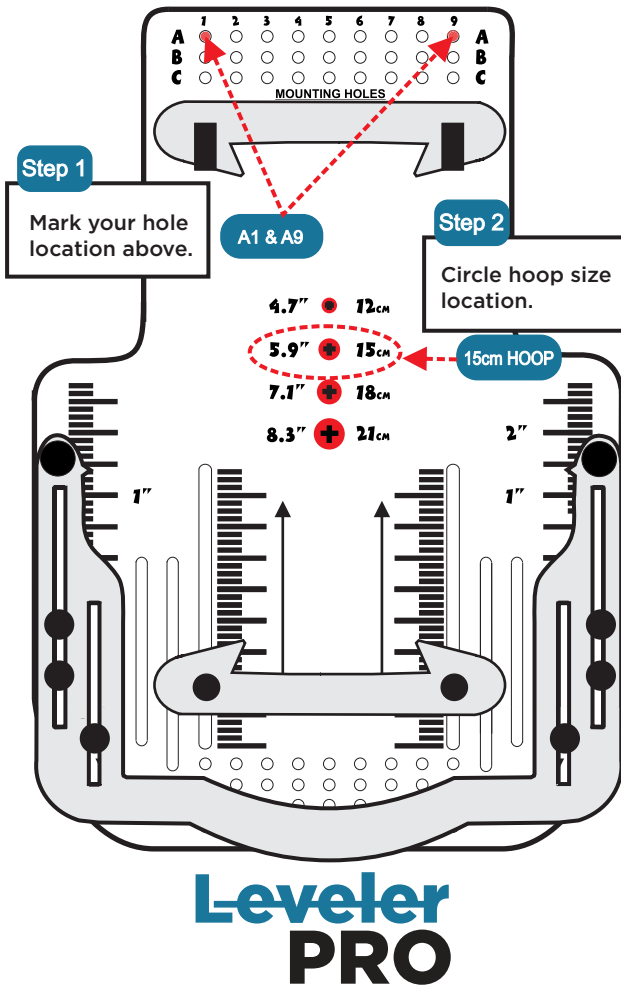

SAMPLE

Leveler Pro

Job Placement Card for Small Hoops

THREE EASY STEPS TO REPEATING YOUR ORDERS

Customer Name _____ Job Design Name _____

Type of Garment _____

Embroidery Location _____

Garment Size ----- Youth ___ Adult ___ ----- Ladies ___ Mens ___

Board Size ----- Infant ___ Youth ___ Adult ___

Step 1 Mark top hole A-B or C and Number 1 thru 9

Example **A1 & A9**

Step 2 Circle hoop size used for this job

Example **5.9" / 15cm**

Step 3 Mark hole location where LevPro was mounted

Mark Holes Below

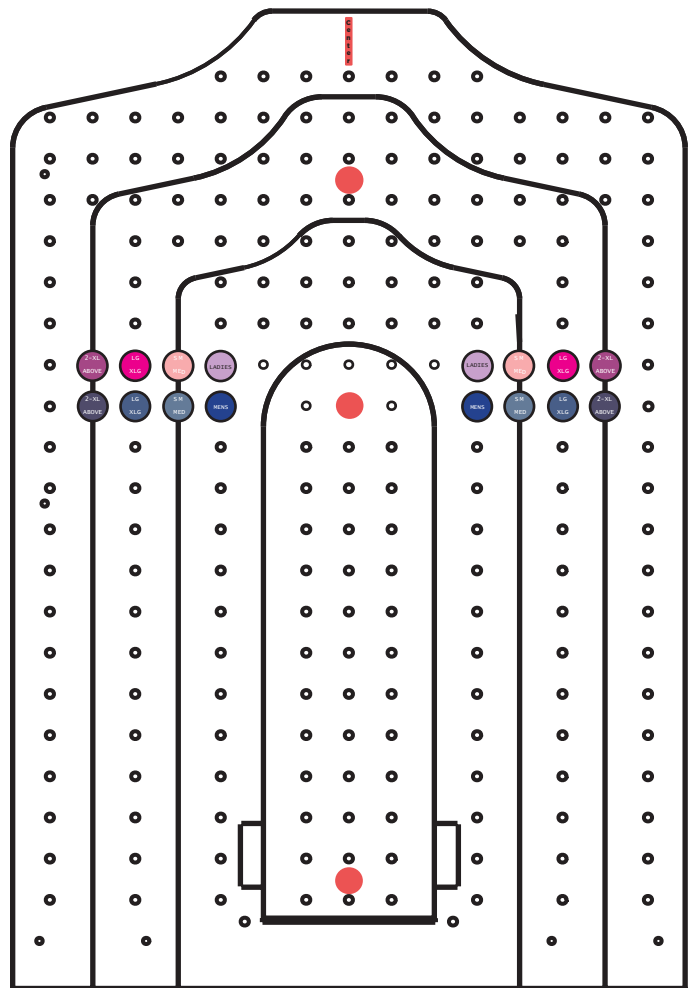

PRINT

Leveler Pro XL

Parts Guide for Large Hoops

Quick Change for Large Tubular Hoops

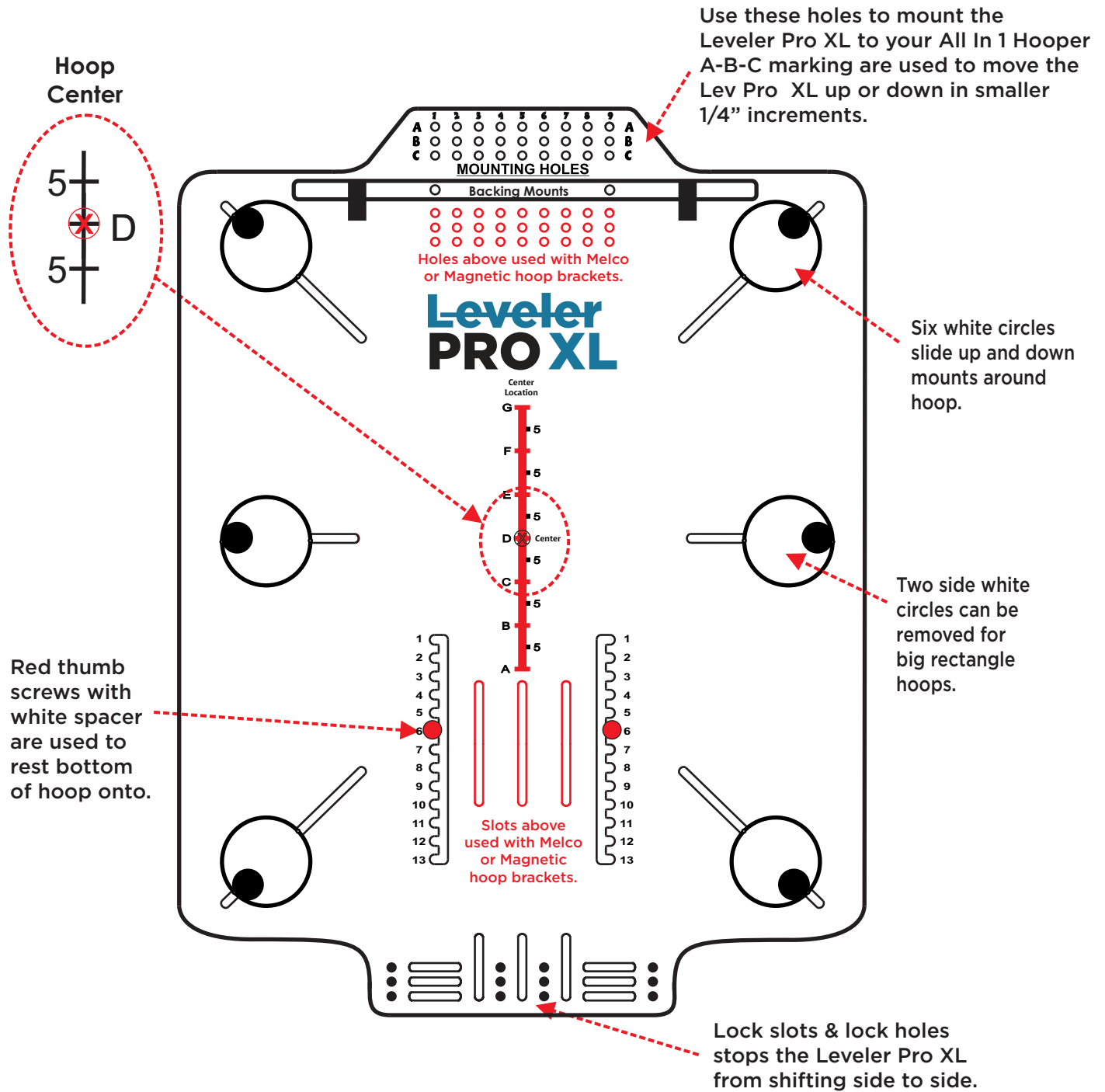



Leveler Pro XL

Job Placement Card for Large Hoops

THREE EASY STEPS TO REPEATING YOUR ORDERS

Customer Name JOHN DOE Job Design Name JD 1
Type of Garment JACKETBACK
Embroidery Location FULL BACK
Garment Size ----- Youth ___ Adult X ----- Ladies ___ Mens X
Board Size ----- Infant ___ Youth ___ Adult X

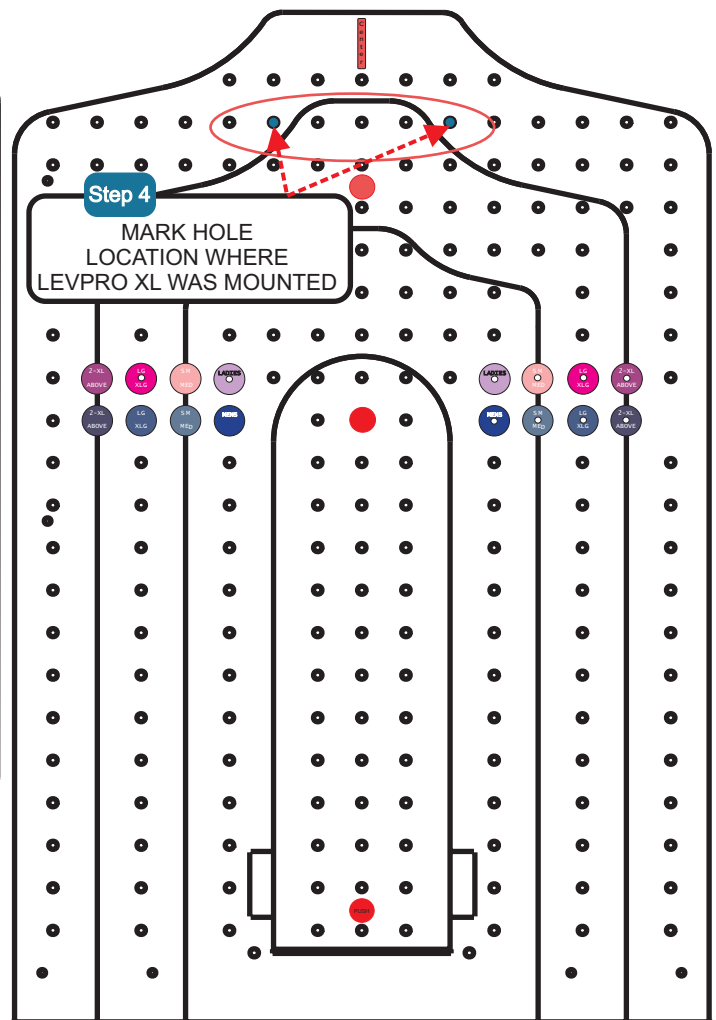
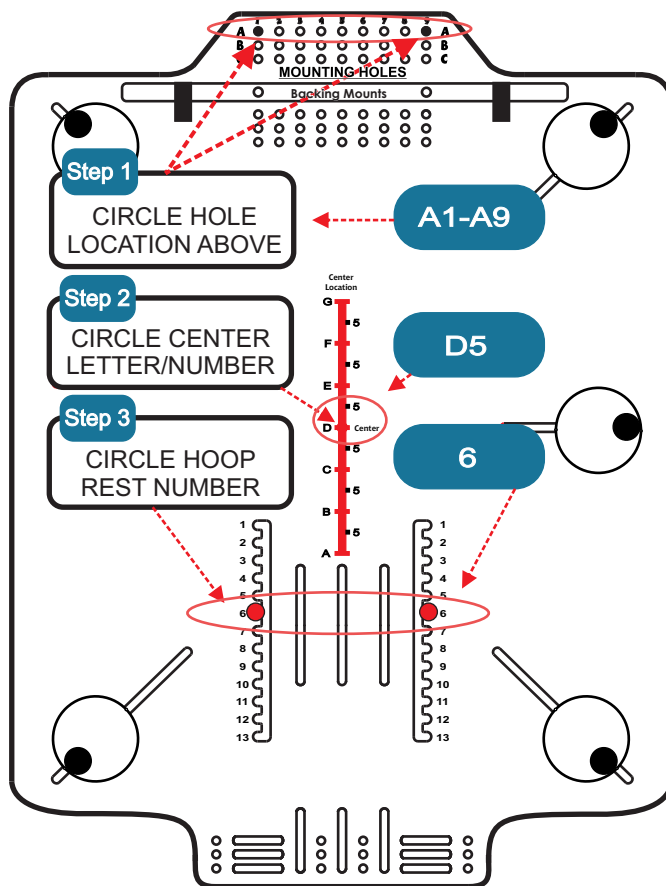

Leveler
PRO XL

SAMPLE

Leveler Pro XL

Job Placement Card for Large Hoops

FOUR EASY STEPS TO REPEATING YOUR ORDERS

Customer Name _____ Job Design Name _____

Type of Garment _____

Embroidery Location _____

Garment Size ----- Youth ___ Adult ___ ----- Ladies ___ Mens ___

Board Size ----- Infant ___ Youth ___ Adult ___

Step 1 Mark top hole A-B or C and Number 1 thru 9 Example A1 & A9

Step 2 Circle center letter / number D5

Step 3 Circle hoop rest number 6

Step 4 Mark hole location where LevPro XL was mounted

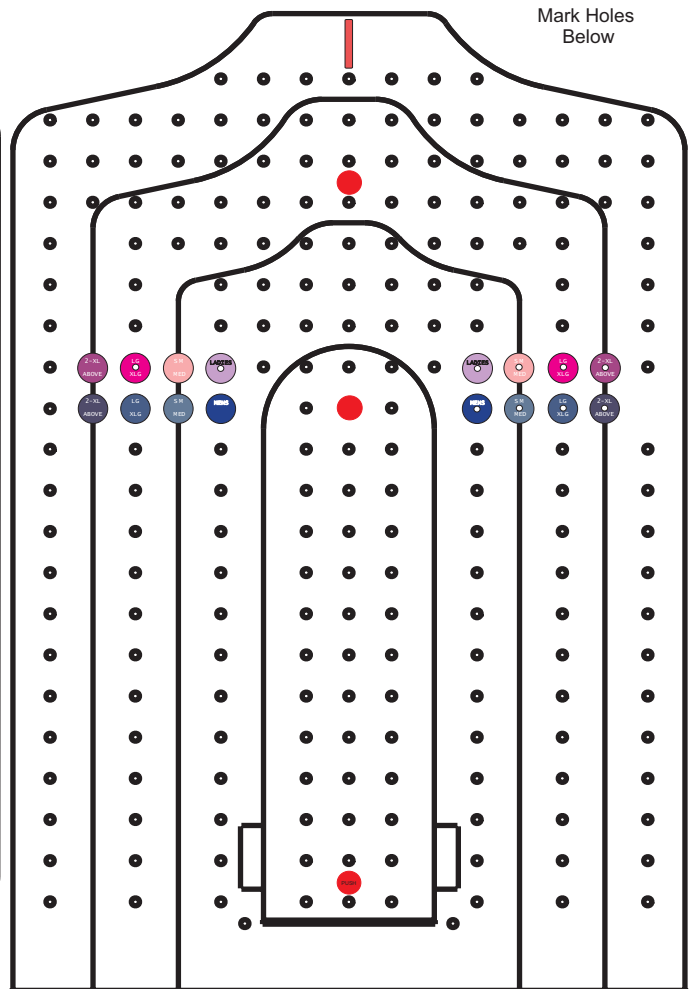
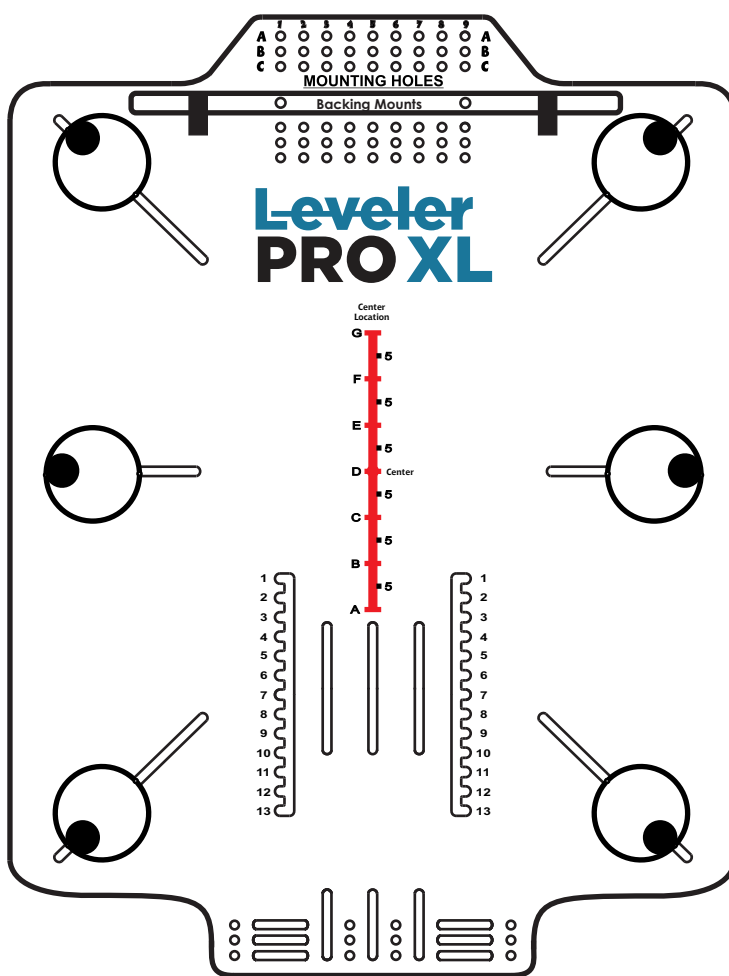

PRINT

Sleeve Board Pro

Parts Guide for Small Hoops

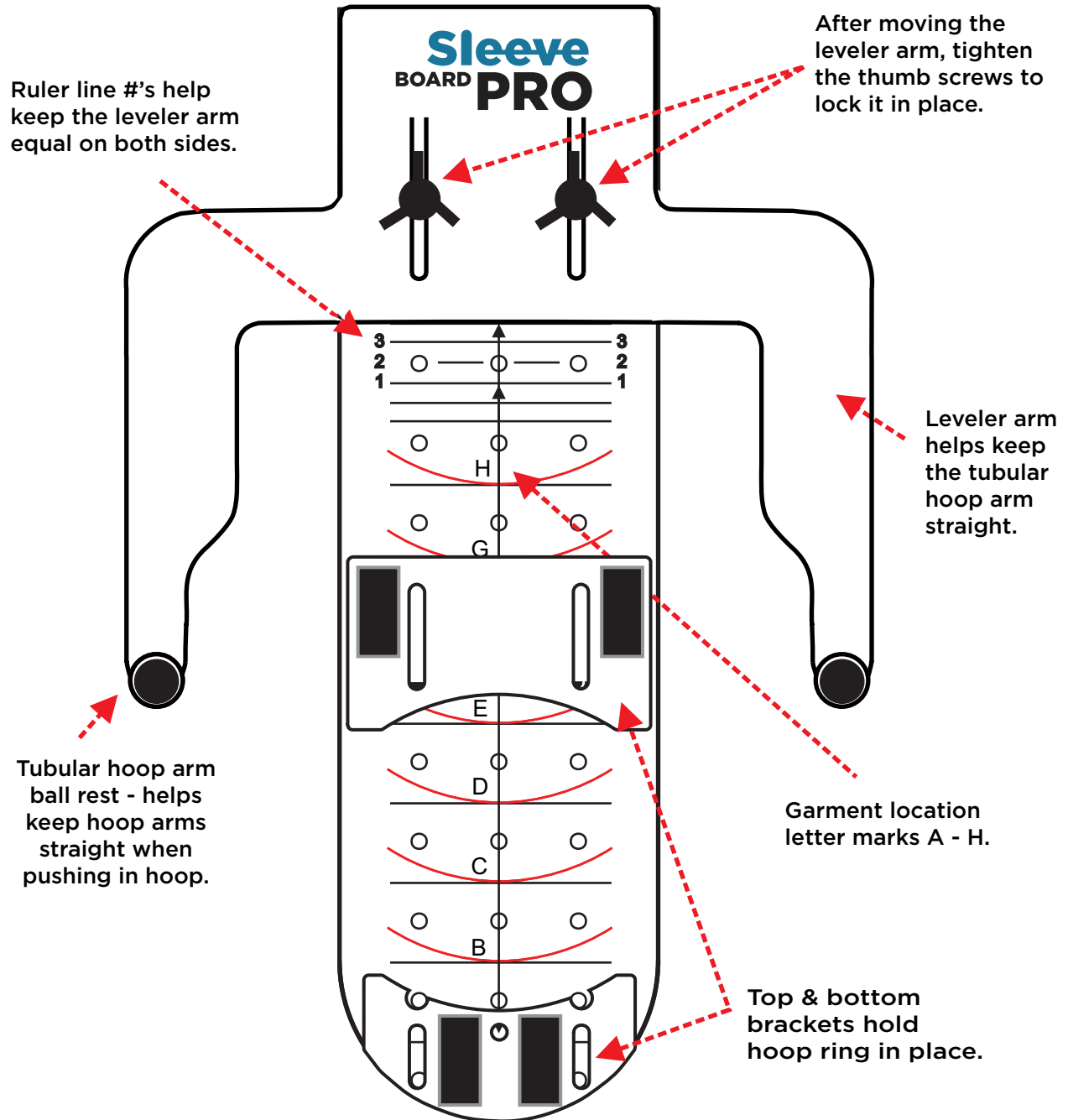

WARNING!

Use Sleeve Board Support under sleeve board!



Sleeve Board Pro

Small Hoops

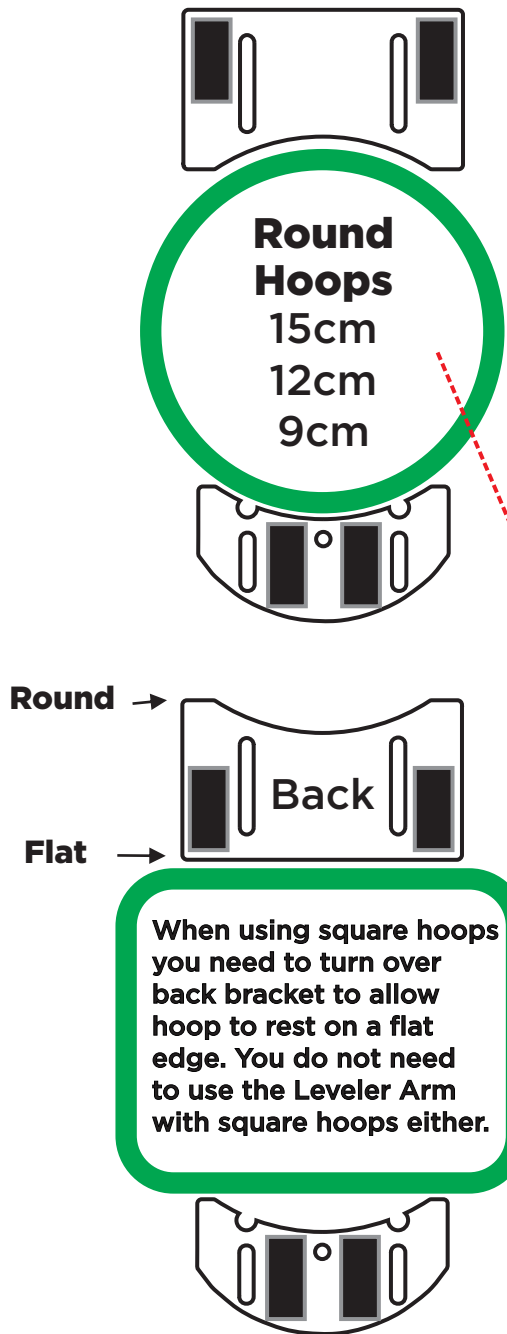

When using square hoops you need to turn over back bracket to allow hoop to rest on a flat edge. You do not need to use the Leveler Arm with square hoops either.

15CM
12CM
9CM

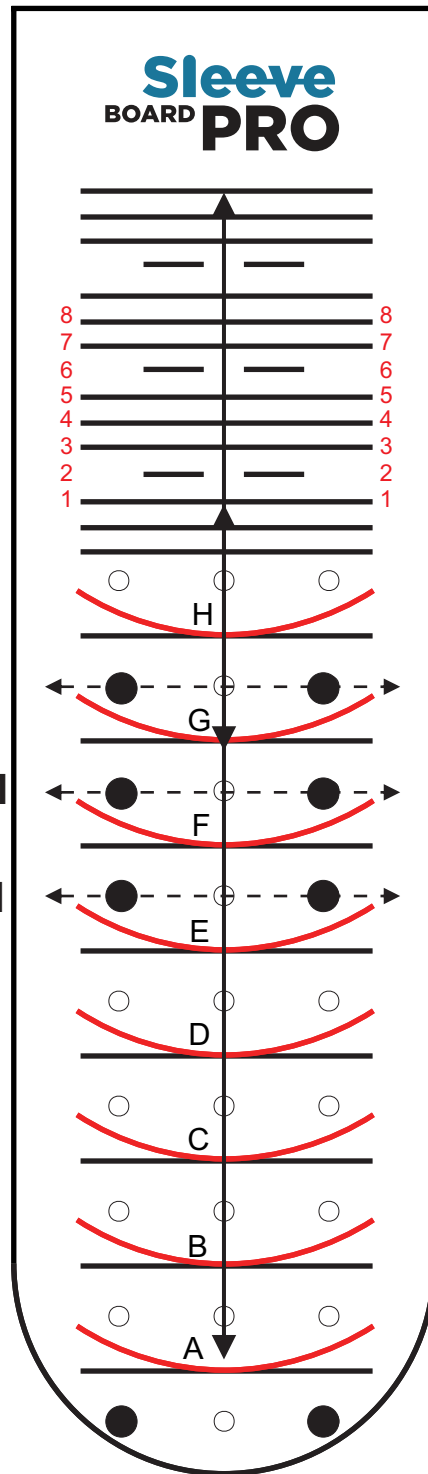

WARNING!

Use Sleeve Board Support under sleeve board!



Sleeve Board Pro

Using Small Hoops

Step 1

Insert both parts of the hoop (hoop ring & outer hoop) in between front & back brackets. Slide back bracket forward and tighten screws.

Step 2

Loosen both black thumb screws and pull the leveler arm forward resting black ball on hoop arm. Tighten thumb screws making sure ruler lines are equal on both sides of the leveler arm.

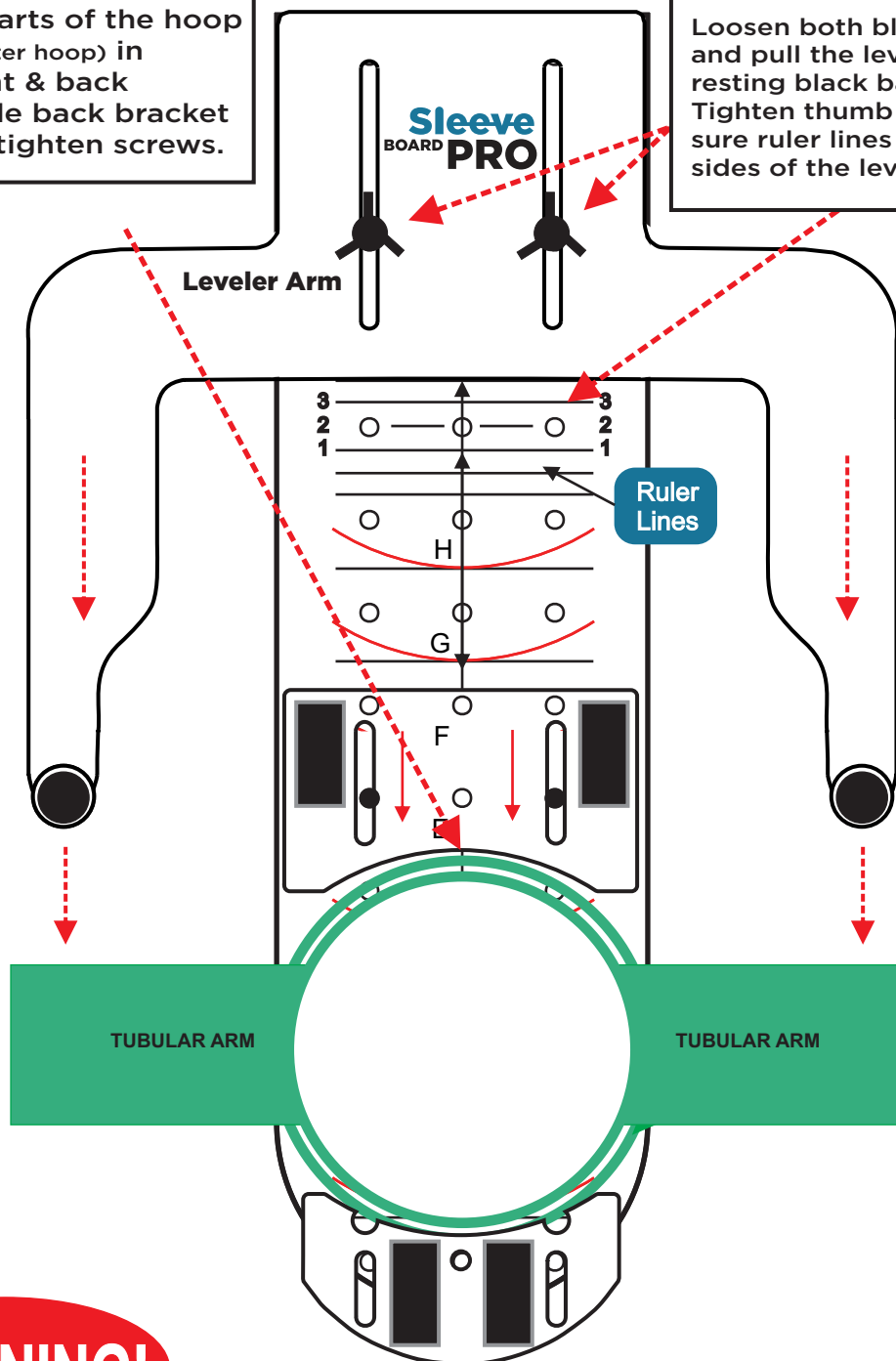

WARNING!

Use Sleeve Board Support under sleeve board!



Sleeve Board Pro

Using Small Hoops

Step 3

Remove top outer hoop leaving the hoop ring on sleeve board. You are now ready to hoop a cap or garment.

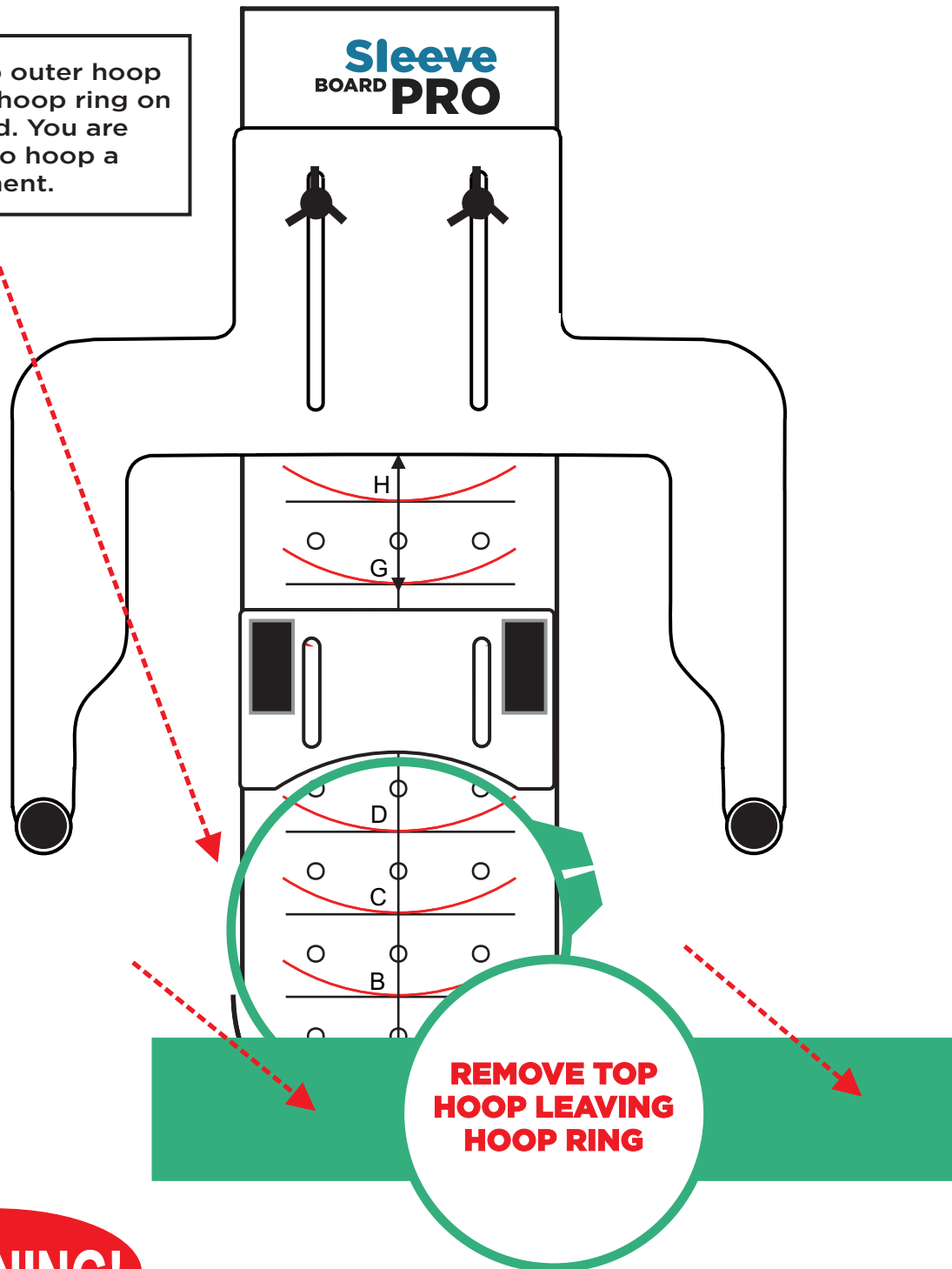

WARNING!

Use Sleeve Board Support under sleeve board!





Sleeve Board Pro

Job Placement Card for Small Hoops

THREE EASY STEPS TO REPEATING YOUR ORDERS

Customer Name **JOE HOOPER** Job Design Name **JH 1**
Type of Garment **CAP - SNAP BACK**
Embroidery Location **BACK OF CAP**
Remarks/Comments **SMALL LETTERING ON BACK OF CAP**
Job Steps # **12EL4= 12CM HOOP =E LOCATION = L LINE =4 RULER LINE**

Step 1

CIRCLE HOOP SIZE

3.5" = 9cm

4.7" = 12cm

5.9" = 15cm

Step 2

LOCATION MARKS

LOCATION LETTER **E**
LINE **X** ARCH _____

Step 3

RULER LINE NUMBER

RULER LINE
NUMBER **4**

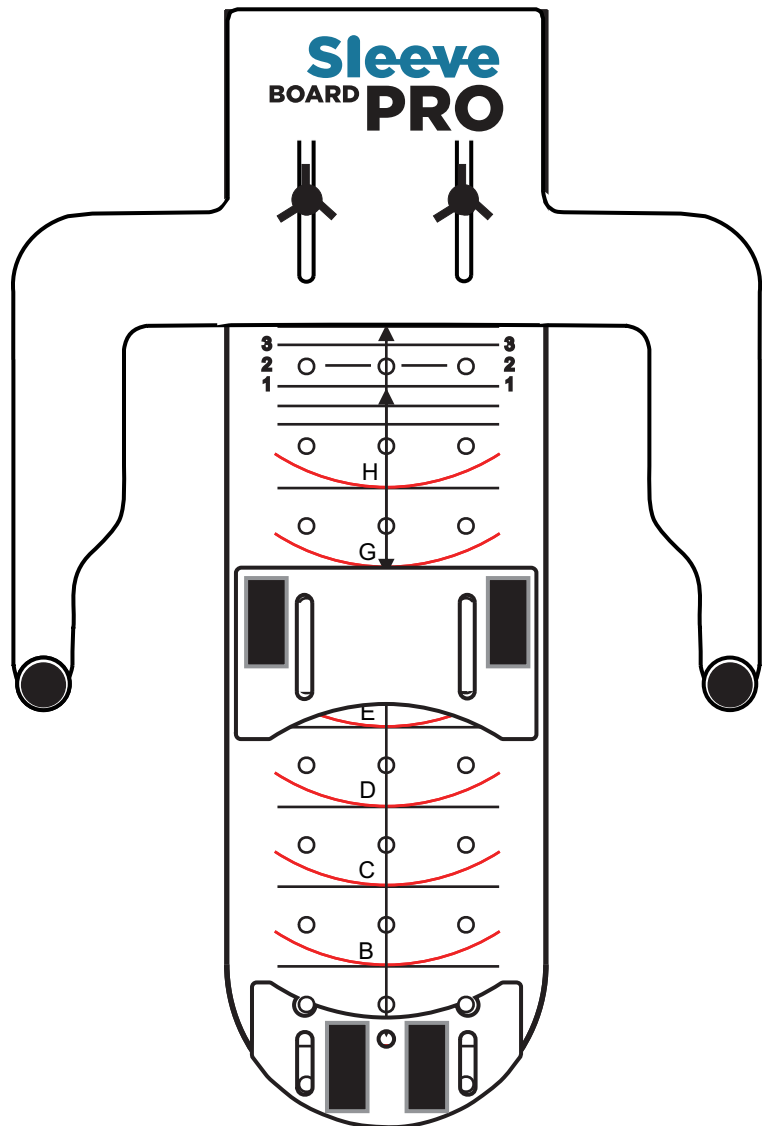

SAMPLE



Sleeve Board Pro

Job Placement Card for Small Hoops

THREE EASY STEPS TO REPEATING YOUR ORDERS

Customer Name _____ Job Design Name _____
Type of Garment _____
Embroidery Location _____
Remarks/Comments _____
Job Steps # _____

Step 1

CIRCLE HOOP SIZE

3.5" = 9cm
4.7" = 12cm
5.9" = 15cm

Step 2

LOCATION MARKS

LOCATION LETTER _____
LINE _____ ARCH _____

Step 3

RULER LINE NUMBER

RULER LINE
NUMBER _____

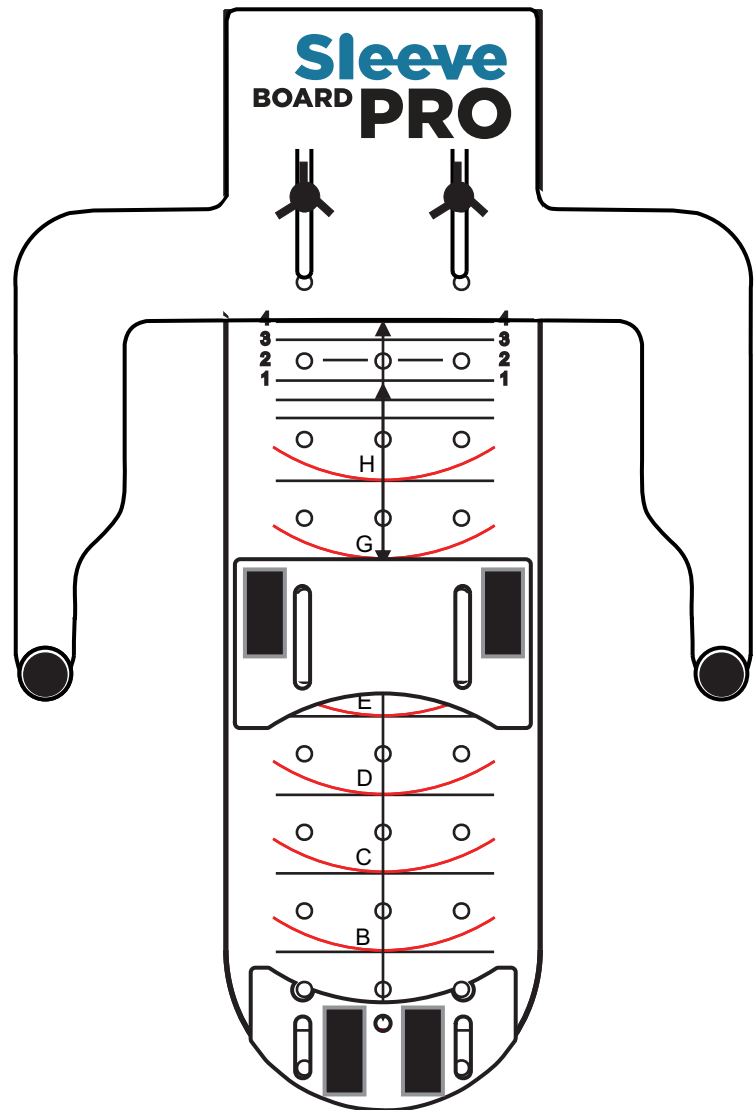

PRINT



TEX INC Support

TEX INC Support
Allin1Hooper.com
Sales@allin1hooper.com
480-375-1844 text/call



www.Allin1Hooper.com